

BREATHING AIR CATALOG

High-Pressure Systems for Safety & Sports Applications



WORLDWIDE QUALITY INNOVATION RELIABILITY

GLOBAL PRESENCE WITH LOCAL SUPPORT





MISSION STATEMENT

Our mission at BAUER COMPRESSORS INC. is to provide the highest quality products and solutions for high-pressure air and gas. We are committed to using the latest technology, best materials, most qualified human resources, and the most efficient fabrication techniques. As a result, our equipment solutions offer superior performance along with best value, and are delivered on time, defect-free and are supported to achieve their maximum potential throughout their entire lifecycle.

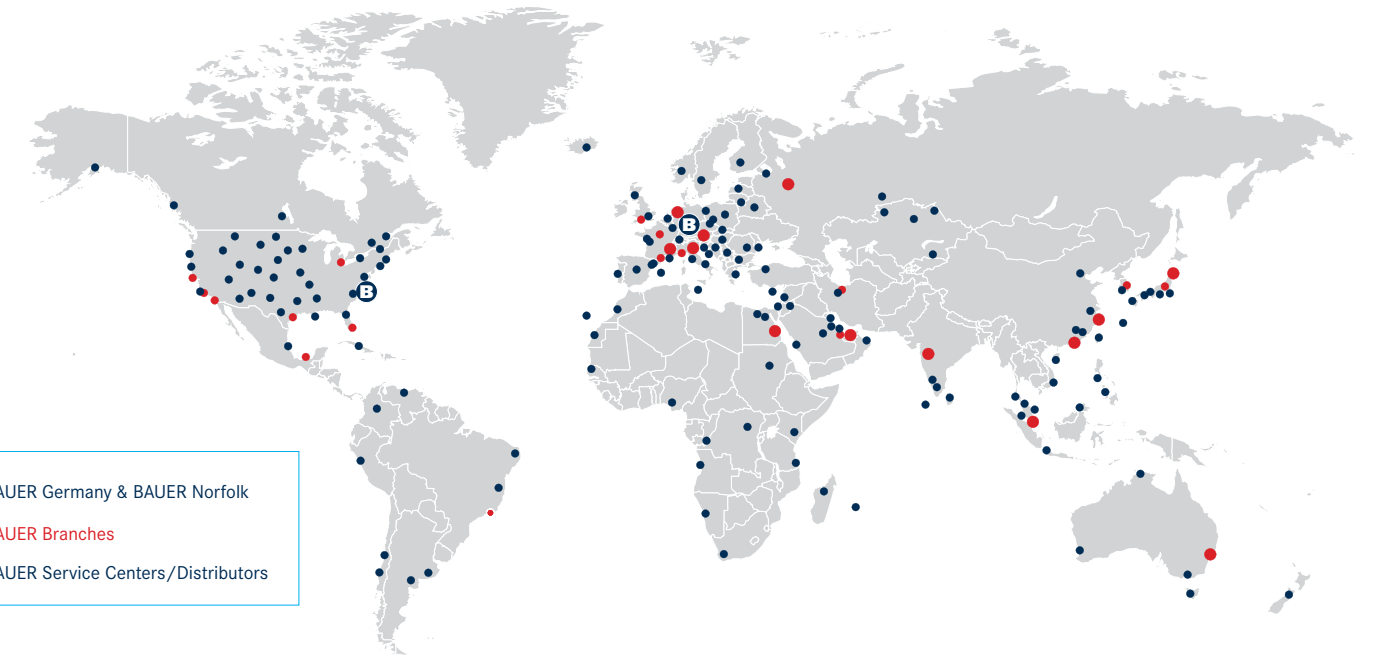
BAUER Corporate Headquarters: North American Manufacturing – Norfolk, Virginia



-  BAUER Germany & BAUER Norfolk
-  BAUER Branches
-  BAUER Service Centers/Distributors

DISTRIBUTOR NETWORK

Supporting you after the sale is a global network of compressor specialists that is unmatched in the industry. Each of our trusted Distributor partners is staffed with BAUER Factory-Trained Technicians and is stocked with a full inventory of products and parts – insuring you receive unsurpassed 24/7 Customer Support, no matter where you are in the world.

Additionally, BAUER has U.S. Sales & Service operations that include branch offices in California and New York.



GLOBAL SUPPORT



SINGLE SOURCE RESPONSIBILITY



LOW COST OF OWNERSHIP



LIFECYCLE PERFORMANCE

OUR EXPERIENCE. YOUR BENEFIT.

Our 75 years of experience continues to be a benefit to our worldwide customers by providing them with a diverse selection of field-proven high-pressure breathing air solutions. We are world renowned for reliability and durability, and BAUER as a company is recognized as the world's foremost innovative designer and manufacturer of high-pressure compressors of the very highest quality.

BAUER's state-of-the-art 250,000 square-foot facility in Norfolk, Virginia means we can stand behind all of the research and development in our breathing-air systems, which are made right here in the U.S.A.



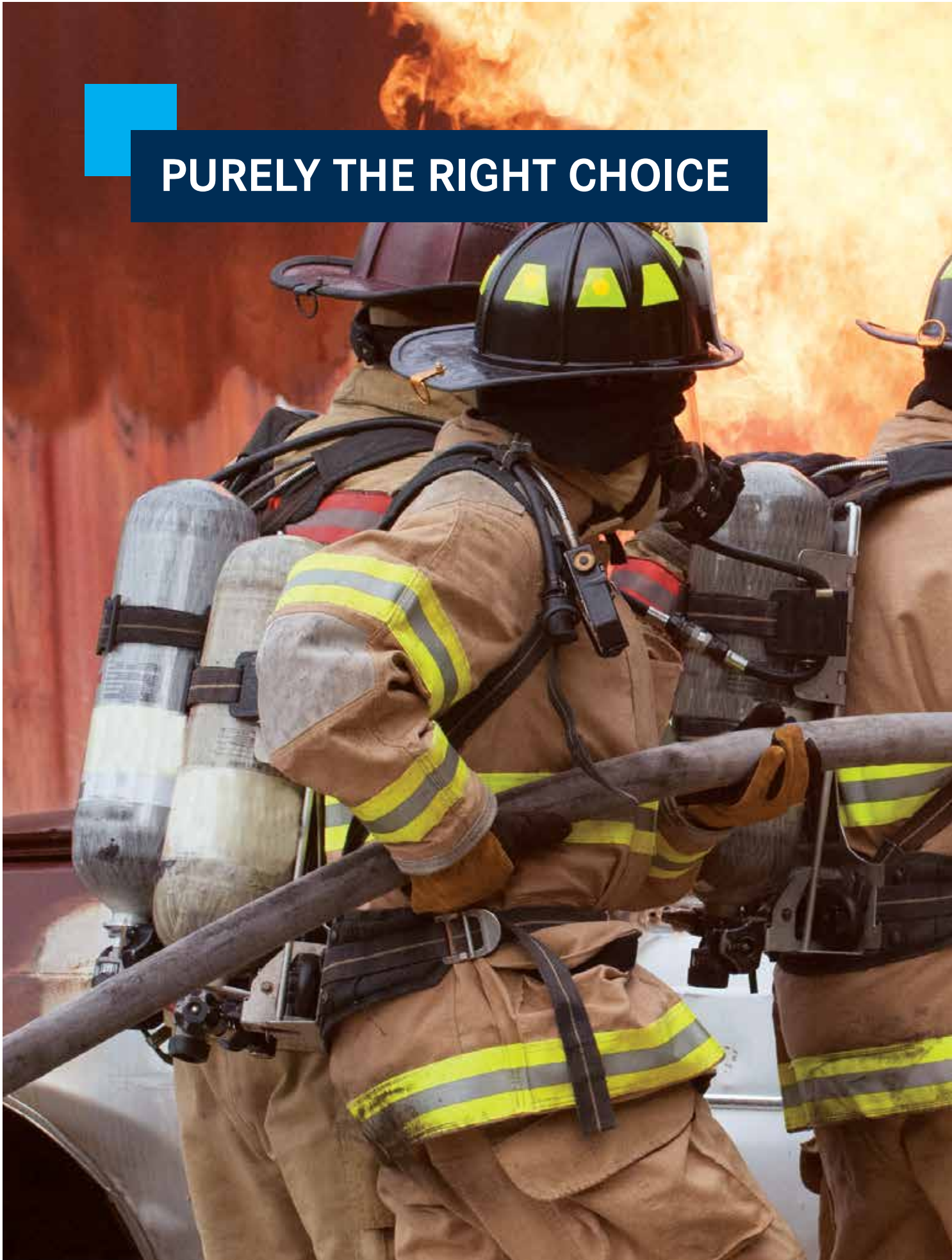

PURELY THE RIGHT CHOICE

CONTENTS

DIVE AND FIRE PRODUCTS

- › VERTECON® 6
- › VERTICUS® 8

FIRE PRODUCTS

- › 7k Systems 10
- › Plus Module 16
- › O320-E/D 18
- › Engine Driven 20
- › TCOM® Trailer 22
- › DDTR25 24
- › TCOM LITE® 26
- › TCOM RC 28
- › TCOM-MS 30
- › Mobile Package 32
- › UNICUS® 4S 34
- › UNICUS® 4i 36
- › Open Designs 40

DIVE PRODUCTS

- › Portables 42
- › DMT II 44

ACCESSORIES

- › CFS5.5® 46
- › Air Storage 48
- › Auto Cascade 50
- › Hose Reels 52
- › B-DETECTION 53
- › BAUER CRC™ 54
- › Purification 56
- › BAUER B-Virus Free™ 58
- › BAUER RFIDPro® 60
- › BAUER CONNECT® for Firefighters 62
- › Quick Reference Guide 64

CUSTOMER SUPPORT

- › Parts, Service, Support & Training 66

D
I
V
E

F
I
R
E

A

C
S

VERTECON®

3-, 4-, AND 5-STAGE OPEN HIGH-PRESSURE BREATHING AIR COMPRESSORS

BAUER's VERTECON® series of high-pressure breathing air compressor systems have been an industry leader for many years. We combined the simplistic platform with an economical design, featuring the latest BAUER technological enhancements. The series now features an integral base that eliminates the guesswork of product placement, ensuring the system has been installed correctly for system ventilation and maintenance accessibility. A refreshed HMI operations panel and electrical control system allow you to tailor the system to your specific requirements. When simple is what you want, look to BAUER.

- › **PRESSURE:**
Up to 6000 PSIG (414 BAR)
- › **CHARGING RATE:**
5 to 26.4 SCFM (142 to 748 L/MIN)
- › **POWER:**
5 to 20 HP (3.7 to 15 kW)



› VERTECON

STANDARD SCOPE OF SUPPLY

- › BAUER breathing air purification system
- › Open vertical cabinet made of formed sheet and plate goods provide a firm foundation for all pressure bearing components
- › Modern design with unsurpassed maintenance accessibility (no hand tools are required for normal maintenance checks and fluid level confirmation)
- › BAUER PLC based controller with 7" color HMI touchscreen display
- › Belt adjustment tool
- › NEMA 4 rated electrical enclosure with UL® listed control panel
- › All wiring harnesses incorporated within a corrugated loom with number coding for easy system diagnosis
- › Emergency stop push button
- › .049 wall thickness stainless steel tubing throughout; no cheap plastic tubing
- › Rugged powder coat finish
- › Zero loss automatic condensate drain system
- › Interstage pressure gauges (locally mounted)
- › Compressor on/off, final pressure, oil pressure and high-temperature shutdown
- › Motor overload indication
- › Final separator counter with shutdown and operator indication
- › Unique integrated positioning base which ensures correct installation every time

TECHNICAL DATA

Model	Charging Rate ¹		Number of Stages	Motor		FAD ²	RPM	Purification System
	SCFM	L/MIN		HP	kW			
5000 PSIG (345 BAR)								
VEC08-E1/E3	8.4	238	3	7.5	5.6	7	1250	P31
VEC20-E3	21	595	4	15	11	17.5	1300	P5
VEC26-E3	26.4	748	4	20	15	22	1350	P5
6000 PSIG (414 BAR)								
VEC05-E1/E3	5	142	3	5	3.7	4	1050	P2
VEC10-E1/E3	9.7	275	4	7.5	5.6	8.1	1180	P2
VEC13-E1/E3	13	368	4	10	7.5	10.8	1420	P2
VEC18-E3	18	510	4	15	11	15	1325	P5
VEC25-E3	25.2	714	5	20	15	21	1300	P5

¹ Based on recharging an 80 cubic foot tank from 500 to 3000 psig.
² Compressor capacity referenced to standard inlet conditions.
 E1= Single phase electric, 230 VAC/60 Hz. E3=Three phase electric, 208/230/460 VAC/60 Hz. Other voltages available on request. Dimensions and weight are approximate and are subject to change.

AVAILABLE ACCESSORIES (FACTORY INSTALLED)

- › BAUER Gas-Tek™ CO monitoring system
- › B-SECURUS - Electronic moisture monitoring for the purification system
- › B-Kool (floor mount only)
- › H₂S monitoring system with audible alarm

SYSTEM FOOTPRINT

- VEC05 - VEC13:**
DIMENSIONS L X W X H inches (mm)
 › 54" x 34" x 56" (1372.6mm x 863.6mm x 1422.4mm)
WEIGHT pounds (kg)
 › 800 - 900 lb (363 - 408.2 kg)
- VEC18 - VEC26:**
DIMENSIONS L X W X H inches (mm)
 › 54" x 34" x 63" (1372.6mm x 863.6mm x 1600.2mm)
WEIGHT pounds (kg)
 › 1200 - 1300 lb (544.3 - 589.7 kg)

DIVE FIRE

DIVE FIRE

VERTICUS®

3-, 4-, AND 5-STAGE ENCLOSED HIGH-PRESSURE BREATHING AIR COMPRESSORS

The days of “Breadbox” designed compressor packages are over! Step up to the BAUER VERTICUS®. The updated, sound-attenuated cabinet is equipped with an aesthetically pleasing operations panel, ensuring easy access to the drive belts. Vertically hinged and lift-off side access doors incorporate fast pin technology for fast removal of the doors for maintenance – no hand tools required! The rear panel incorporates integral handles and a tabbed lift-off design. The front access door includes a hex-keyed latch to eliminate any accidental door openings while the system is operating. Sound attenuation has been incorporated on every possible panel to provide a nice and quiet operating level of approximately 72 dB (within one meter). One package size accommodates BAUER high-pressure air-cooled compressors from 5 to 20 Hp motors. Our new, larger, 7” HMI enhances the monitoring of system functions.

- › **PRESSURE:**
Up to 6000 PSIG (414 BAR)
- › **CHARGING RATE:**
5 to 26.4 SCFM (142 to 748 L/MIN)
- › **POWER:**
5 to 20 HP (3.7 to 15 kW)



› VERTICUS

STANDARD SCOPE OF SUPPLY

- › BAUER breathing air purification system with B-SECURUS
- › BAUER PLC based controller with 7” color HMI touchscreen display
- › NEMA 4 rated electrical enclosure with UL® listed control panel
- › Compressor low oil pressure and high-temperature safety shutdowns
- › Emergency stop push button and automatic start/stop control
- › Zero loss automatic condensate drain system with non-corrosive condensate reservoir and integrated float sensor and automatic “Full” indication and compressor shutdown
- › Interstage pressure gauges (locally mounted)
- › Vertically hinged front operations panel and lift-off side maintenance access doors
- › Inlet filter maintenance indicator
- › Unique hinged front operations panel
- › Unique air induction plenum ensures optional cooling air flow

AVAILABLE ACCESSORIES (FACTORY INSTALLED)

- › BAUER Gas-Tek™ CO monitoring system
- › B-Kool
- › H₂S monitoring system with audible alarm

SYSTEM FOOTPRINT

- VERTICUS:**
VAC5 - VAC26
DIMENSIONS L X W X H inches (mm)
 › 55” x 35” x 70” (1397mm x 737mm x 1778mm)
WEIGHT pounds (kg)
 › 1000 - 1400 lb (453.6 - 635 kg)

TECHNICAL DATA

Model	Charging Rate ¹		Number of Stages	Motor		FAD ²	RPM	Purification System
	SCFM	L/MIN		HP	kW			
5000 PSIG (345 BAR)								
VAC20-E3	21	595	4	15	11	17.5	1300	P5 B-SECURUS
VAC26-E3	26.4	748	4	20	15	22	1350	P5 B-SECURUS
6000 PSIG (414 BAR)								
VAC5-E1/E3	5	142	3	5	3.7	4	1050	P2 B-SECURUS
VAC08-E-1/E3	8	227	3	7.5	5.6	7	1450	P2 B-SECURUS
VAC10-E1/E3	9.7	275	4	7.5	5.6	8.1	1180	P2 B-SECURUS
VAC13-E1/E3	13	368	4	10	7.5	10.8	1420	P2 B-SECURUS
VAC18-E3	18	510	4	15	11	15	1325	P5 B-SECURUS
VAC25-E3	25.2	714	5	20	15	21	1300	P5 B-SECURUS

1) Based on recharging an 80 cubic foot tank from 500 to 3000 psig.
 2) Compressor capacity referenced to standard inlet conditions.
 3) 30 HP units are in a cabinet other than depicted.
 E1= Single phase electric, 230 VAC/60 Hz. E3=Three phase electric, 208/230/460 VAC/60 Hz. Other voltages available on request. Dimensions and weight are approximate and are subject to change.

DIVE FIRE

DIVE FIRE

7000 PSIG Breathing Air Systems



F
I
R
E

7000 PSIG HIGH-PRESSURE BREATHING AIR COMPRESSORS SYSTEMS

As SCBA working pressures increase, so must the fire department's high-pressure breathing air compressor system. If left unchecked, the department runs the risk of not supporting their breathing air demand for grade "E" breathing air. BAUER Compressors is the first company in the industry to offer a wide and varied product portfolio to meet your specific needs. We start with a performance-proven BAUER air-cooled high-pressure compressor **designed, built, and rated** for continuous duty operations at 7000 PSIG. The compressor has been in existence long before others. It has proven itself since 1992 in the high-pressure, non-breathing air market where up-time demands are far more stringent than the breathing air market. We couple the compressor to one of our BAUER high-pressure breathing air purification systems, designed for continuous operations at 7000 PSIG while meeting the Compressed Gas Association's rigorous breathing air quality standards for grade "E" air and/or the National Fire Protection Association (1989 standard for high-pressure breathing air) along with many other recognized global standards.

BAUER Compressors offers two (2) models of 7000 PSIG compressor packages, each outfitted to meet your specific requirements. A simplistic component system utilizing one of our VERTECON® compressor packages. Along with an independently tested and verified CFS5.5®-3S or CFS5.5®-2S SCBA containment fill station and an ASME coded air storage system; Or step up to either a UNICUS® 4S or UNICUS® 4i All-In-One compressor package, each outfitted to meet your specific needs. No matter which compressor system you select, rest assured all of the components were chosen in strict adherence to NFPA 1901-2016 edition, calling for a 4:1 structural safety factor.

VERTECON® STANDARD SCOPE OF SUPPLY

- › BAUER breathing air purification system
- › Open vertical cabinet made of formed sheet steel providing a firm foundation for all pressure bearing components
- › Modern design with unsurpassed maintenance accessibility (no hand tools are required for normal maintenance checks and fluid level confirmation)
- › BAUER PLC based controller with 7" color HMI touchscreen display
- › Self-adjusting drive belt tensioner
- › NEMA 4 rated electrical enclosure with UL® listed control panel
- › All wiring harnesses incorporated within a corrugated loom with number coding for easy system diagnosis
- › Emergency stop push button
- › Stainless steel tubing throughout, no cheap plastic tubing
- › Rugged powder coat finish
- › Automatic condensate drain system with integral reservoir level sensor to provide system shutdown when the reservoir is full
- › Interstage pressure gauges (locally mounted)
- › SECURUS Moisture Monitor

SYSTEM FOOTPRINT

DIMENSIONS L X W X H inches (mm)

- › 54" x 34" x 63" (1372mm x 864mm x 1600mm)

WEIGHT pounds (kg)

- › 1075 lb (488 kg)



› VERTECON/7K

F
I
R
E

PLC CONTROLLER

- › Compressor on/off, final pressure, oil pressure, high temperature shutdown
- › Supports automatic condensate drain system
- › Motor overload indication
- › Final separator counter with shutdown and operator indication

AVAILABLE ACCESSORIES (FACTORY INSTALLED)

- › BAUER Gas-Tek™ CO monitoring system
- › H₂S monitoring system

TECHINICAL DATA

Model	Block	Charging Rate ¹		Number of Stages	Motor		FAD ²	RPM	Purification System
		SCFM	L/MIN		HP	kW			
7000 PSIG (476 BAR)									
VTC-7K/20	IK18.11I	20	566	5	20	15	17	1300	P5 B-SECURUS
VTC-7K/15	IK15.11	13	368	4	15	11	11	960	P5 B-SECURUS

1) Based on recharging an 80 cubic foot tank from 500 to 3000 psig. 2) Compressor capacity referenced to standard inlet conditions. E3=Three phase electric, 208/230/460 VAC/60 Hz. Other voltages available on request.



› CFS5.5®-2S/7K



› CFS5.5®-3S/7K

FIRE

CFS5.5®

STANDARD SCOPE OF SUPPLY

- › Complete with SCBA fill connection, fill hose and bleed valve
- › Fill control panel with an adjustable regulator, relief valve, manual control valve and pressure gauge for each fill position
- › Convenient door handle actuation, bottom venting and reduced footprint
- › Hands-free door interlock
- › Compliant with NFPA 1901 2016 Edition
- › Four bank dual function cascade controls
- › Air direction valve

SYSTEM FOOTPRINT

CFS5.5®-3S

DIMENSIONS L X W X H inches (mm)

- › 41" x 21" x 57" (1041mm x 533mm x 1448mm)

WEIGHT pounds (kg)

- › 1000 lb (454 kg)

CFS5.5®-2S

DIMENSIONS L X W X H inches (mm)

- › 30" x 21" x 57" (762mm x 533mm x 1448mm)

WEIGHT pounds (kg)

- › 750 lb (390.2 kg)

TECHINICAL DATA

Model	Description
CFS5.5®-2S	Two position CFS equipped with inlet pressure gauge adjustable regulator, regulated pressure gauge, fill control valve and fill pressure gauges. Unit will consist of Dual function, top mount, four bank cascade panel. The dual function feature offers the ability to refill a storage bank, even with the bank valve closed, while filling SCBA's from another bank. It also includes an air direction valve allowing the operator to select "fill from storage" or "fill from compressor", additionally the system includes a regulated remote fill outlet.
CFS5.5®-3S	Three position CFS equipped with inlet pressure gauge adjustable regulator, regulated pressure gauge, fill control valve and fill pressure gauges. Unit will consist of Dual function, top mount, four bank cascade panel. The dual function feature offers the ability to refill a storage bank, even with the bank valve closed, while filling SCBA's from another bank. It also includes an air direction valve allowing the operator to select "fill from storage" or "fill from compressor", additionally the system includes a regulated remote fill outlet.

AIR STORAGE STANDARD SCOPE OF SUPPLY

- › The scope of supply for the ASME cylinder assembly includes four ASME coded cylinders, an ASME safety relief valve, cylinder valve and drain valve for each cylinder
- › Assemblies are designed to be used with a BAUER four-bank cascade panel. Gauges are not included on the individual cylinders as they are on the cascade pane.
- › ASME-7K-3:1 is a heavy-duty, welded steel rack designed for vertical cylinder configuration for stationary or mobile applications. Each cylinder is independently affixed to the rack with unistrut type clamps
- › ASME-7K-4:1 is a heavy-duty, welded steel rack designed for horizontal cylinder configuration for stationary applications. Each cylinder is independently affixed to the rack with clamps

SYSTEM FOOTPRINT

ASME-7K-3

DIMENSIONS L X W X H inches (mm)

- › 52" x 17.5" x 69.5" (1320.8mm x 444.5mm x 1765.3mm)

WEIGHT pounds (kg)

- › 2000 lb (3220 kg)

ASME-7K-4

DIMENSIONS L X W X H inches (mm)

- › 95" x 34" x 44" (2413mm x 864mm x 1118mm)

WEIGHT pounds (kg)

- › 7100 lb (3220 kg)



› ASME-7K-3:1

FIRE

TECHINICAL DATA

Model	Description
ASME - 7K-3:1	4 Cylinder System with maximum operating pressure of 7000 PSIG installed in a vertical rack. System shall provide a 3:1 structural safety factor
ASME - 7K-4:1	4 Cylinder System with maximum operating pressure of 7000 PSIG installed in a horizontal rack. System shall provide a 4:1 structural safety factor

7000 PSIG ALL IN ONE SYSTEM: UNICUS® 4S & 4i

BAUER COMPRESSORS, INC. is the first company to offer a fully unitized compressor system built for 7000 PSIG service. Let's start with continuous duty BAUER 7000 PSIG compressors, which were in existence well before others put pen to paper. We couple the compressor to a BAUER high pressure breathing air purification system that meets the rigorous CGA, NFPA, and many other global standards for high pressure breathing air. A sound attenuated cabinet enclosure incorporates a four (4) cylinder 7000 PSI ASME air storage system along with an NFPA compliant 3-position containment SCBA fill station. Operations and systems functions are simplified with everything located on a centrally located and illuminated operations panel, including an ergonomic and intuitive HMI touchscreen.

Additionally, we are offering you two (2) modes of operation, analog or automatic. The UNICUS® 4S is your choice for all things manually controlled. Should your department wish the automated path, select the UNICUS® 4i. If you want to dress your unit in concert with the Fire Departments theme, ask about our Fire Edition package. Look to BAUER COMPRESSORS when your department needs the best all-in-one compressor system on the market today, backed by our global network of service partners.

FIRE

- › **PRESSURE:**
Up to 7000 PSIG
(483 BAR)
- › **CHARGING RATE:**
13 to 20 SCFM
(368 to 566 L/MIN)
- › **POWER:**
15 to 20 HP
(11 to 15 kW)

7K



› UNICUS® 4i /7K



OPTIONAL

UNICUS® 4i
FIRE EDITION
OPTIONAL FIRE EDITION PAINT SCHEME
(SHOWN HERE)

STANDARD SCOPE OF SUPPLY

- › BAUER breathing air purification system with B-SECURUS
- › BAUER PLC based controller with 7" color HMI touchscreen display on 4S; 15" HMI on 4i
- › NEMA 4 rated electrical enclosure with UL® listed control panel
- › Compressor low oil pressure and high temperature safety shutdowns
- › Emergency stop push button
- › Hinged cascade fill control panel with Lexan laminate air flow/fill schematic
- › Audible alarm on safety shutdowns
- › Inlet filter maintenance indicator
- › Automatic condensate drain system with non-corrosive condensate reservoir and integrated float sensor and automatic "Full" indication and compressor shutdown
- › Four (4) ASME 7000 PSI code stamped air cylinders; Cylinders are rated with a 3:1 SF
- › Sound attenuating enclosure with 1/4" latches and lift-off type hinges
- › NFPA 1901 2016 edition compliant 3 position containment fill station accommodates SCBA or SCUBA cylinders up to 31" overall length
- › Manually controlled dual-function 4 bank cascade controls with air direction valve are standard on the 4S models; Automatic cascade controlled logic is standard on the 4i models
- › RFID SCBA data logging integrated into fill station (UNICUS 4i)

AVAILABLE ACCESSORIES (FACTORY INSTALLED)

- › BAUER Gas-Tek™ CO monitoring system
- › BAUER RFIDPro™ SCBA data logging (UNICUS 4S)
- › RFID data tags (UNICUS 4i & UNICUS 4S)
- › 100 ft high-pressure cabinet enclosed hose reel
- › Panel mounted remote fill hose connection
- › Dual Fill-all SCBA positions
- › Tri Fill-all SCBA positions

SYSTEM FOOTPRINT

DIMENSIONS L x W x H inches (mm)

- › 101" x 38" x 80" (2565mm x 965mm x 2032mm)

WEIGHT pounds (kg)

- › 4350 - 4550 lb (1973 - 2064 kg)

TECHNICAL DATA

Model	Charging Rate ¹		Number of Stages	Motor		FAD ²	RPM	Purification System
	SCFM	L/MIN		HP	kW			
7000 PSIG (483 BAR)								
UN 4S-15/7K	13	368	4	15	11	10.8	960	P5 B-SECURUS
UN 4S-20/7K	20	566	5	20	15	17	1300	P5 B-SECURUS
UN 4i-15/7K	13	368	4	15	11	10.8	960	P5 B-SECURUS
UN 4i-20/7K	20	566	5	20	15	17	1300	P5 B-SECURUS

1) Based on recharging an 80 cubic foot tank from 500 to 3000 psig. 2) Compressor capacity referenced to standard inlet conditions. E3=Three phase electric, 208/230/460 VAC/60 Hz. Other voltages available on request. Dimensions and weight are approximate and are subject to change.

OPTIONAL ACCESSORIES - 7000 SERIES UNICUS 4S & UNICUS 4I

Item	Description	
0001	BAUER Gas-Tek™ Electronic carbon monoxide monitor complete with calibration kit wired for alarm and shutdown. (calibration gas included)	GT/CO/III
0002	Panel mounted remote fill hose connection. Includes bulkhead fitting, adjustable regulator for up to 6000 PSIG service, gauge, isolation valve and quick connect/disconnect fitting (hose no included)	/RF/REG
0003	UN4 remote fill hose connection including adjustable regulator for up to 6000 PSIG service, gauge and isolation valve connected to a cabinet enclosed hose reel with 100 feet of hose rated for 6000 PSIG service	UN4/RF/REL-9
0004	DUAL-FILL, high/low, quick connect fill system (specify fill pressures)	DUAL-FILL/3 position
0005	TRI-FILL, high/low/SCUBA, quick connect fill system (specify fill pressures)	TRI-FILL/3 position
0006	Fire Edition paint scheme	
FOR UNICUS® 4i ONLY		
0007	RFID SCBA Data Logging	RFID4i
0008	RFID DATA TAGS Each Kit includes 25-each tags	KIT-0557

FIRE

PLUS MODULE

3- AND 4-STAGE MULTI-FUNCTIONAL HIGH-PRESSURE BREATHING AIR COMPRESSORS VERTICUS PLUS®

The same package amenities found in the VERTICUS® high pressure breathing air compressor system, plus a free-standing aesthetically pleasing multi-functional fill station module, are combined to create the BAUER VERTICUS PLUS®. BAUER's performance-proven CFS5.5®-2S NFPA compliant containment fill station; two (2) bank dual function cascade controls; integral air storage rack with two (2) UN/ISO code air storage cylinders; 3-way selector valve to select either air from the compressor or onboard air storage system all come together creating the ultimate fill station. Install the two (2) modules side by side as an all-in-one configuration or apart based on the installation site specifics. Flexibility is the key; look to BAUER to unlock the possibilities.

› CONFIGURATION 1

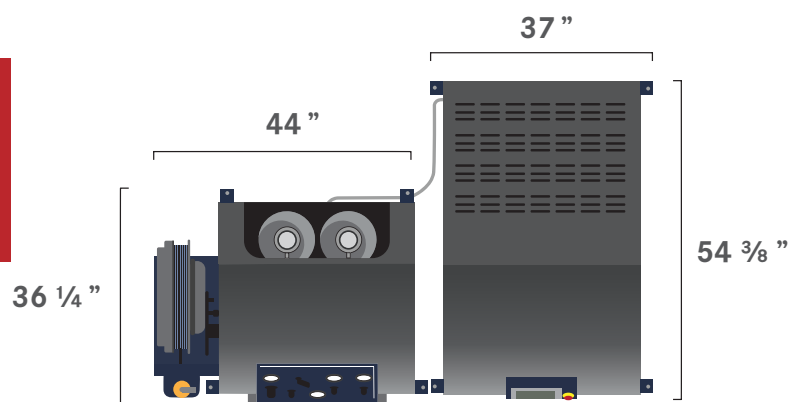

Fill station module showing optional hose reel

› CONFIGURATION 2

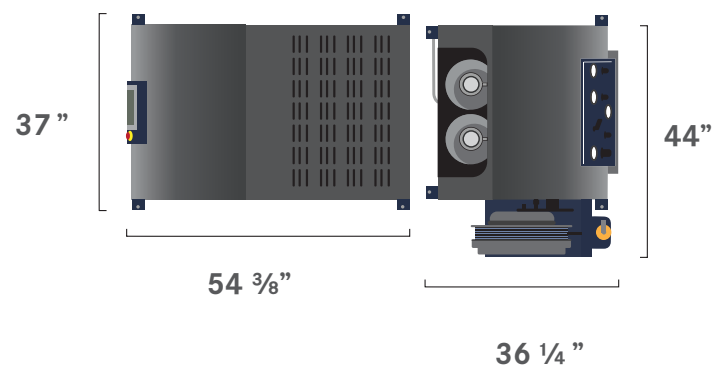

Fill station module showing optional hose reel

NOW AVAILABLE IN TWO NEW EXCITING OFFERINGS!

VERTECON® PLUS

BAUER's series of high-pressure breathing air compressor systems have been an industry leader for many years. An economical design featuring the latest BAUER technological enhancements and unsurpassed maintenance accessibility is incorporated within the simplistic platform. The series now features an integral base that eliminates the guesswork of product placement, ensuring the system has been installed correctly for system ventilation and maintenance accessibility.

Matched with the VERTECON® Compressor is the CFS5.5®-2/PLUS: A two-position Fully NFPA Compliant (1901 & 1989) SCBA/SCUBA Fill Station. The CFS5.5®-2/PLUS includes an attractive, ergonomically designed, two-bank Cascade Fill Control Panel and an integral air storage system consisting of two 6000 PSIG UN/ISO air storage cylinders. The VERTECON® PLUS System can be further enhanced by the substitution of ASME air storage cylinders in lieu of UN and the addition of the optional Regulated Remote Fill Outlet, including a high-pressure hose reel and 100 ft. of 6000 PSIG High-Pressure Hose!



Fill station module showing optional hose reel

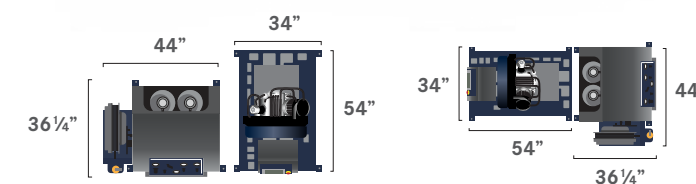

› CONFIGURATION 1

› CONFIGURATION 2

BAUER LEGACY® PLUS

The BAUER LEGACY™ Series built in the rugged and proven VERTECON® Frame offers "Back To Basics Simplicity" while still incorporating PLC Control! Replacing the HMI/Touchscreen will be a simple, illuminated On/ Off Switch and a set of flashing indicator lamps; the lamps will flash a code representing fault warnings and shutdowns.

Matched with the BAUER LEGACY™ Compressor is the CFS5.5®-2/PLUS: A two-position Fully NFPA Compliant (1901 & 1989) SCBA/SCUBA Fill Station. The CFS5.5®-2/PLUS includes an attractive, ergonomically designed, two-bank Cascade Fill Control Panel and an integral air storage system consisting of two 6000 PSIG UN/ISO air storage cylinders. The BAUER LEGACY™ System can be further enhanced by the substitution of ASME air storage cylinders in lieu of UN/ISO and the addition of the optional Regulated Remote Fill Outlet including a high-pressure hose reel and 100 ft. of 6000 PSIG High-Pressure Hose!



Fill station module showing optional hose reel

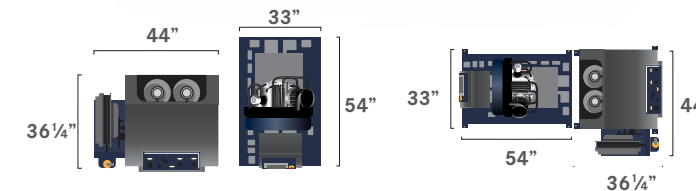

› CONFIGURATION 1

› CONFIGURATION 2

FIRE

FIRE

0320-E/D

4-STAGE HIGH PRESSURE BREATHING AIR COMPRESSORS

The 0320-E/D series of compressors are your solution for onshore and offshore applications when an efficient compressor is required for the budget consciousness oil and gas market. Corrosion resistant components, which are assembled and tubed with stainless steel fasteners and fittings, make the 0320-E/D an ideal choice when a robust compressor is required for the extremes of the drilling environment. Enhanced purification and diesel engine upgrades allow us to have third party certification for operations at temperatures up to 55°C (131°F).



› 0320-E/D
(SHOWN WITH OPTIONAL CO AND H₂S MONITORS)

- › **PRESSURE:**
Up to 6000 PSIG (414 BAR)
- › **CHARGING RATE:**
13 SCFM (368 L/MIN)
- › **POWER:**
10 to 18 HP (7.5 to 13 kW)



STANDARD SCOPE OF SUPPLY

- › BAUER breathing air purification system
- › TEFC motor
- › NEMA 4 rated electrical enclosure with **UL**® listed control panel
- › Compressor low oil pressure and high temperature safety shutdowns
- › Emergency stop push button
- › Automatic condensate drain system with non-corrosive condensate reservoir and integrated float switch and automatic “Full” indication and compressor shutdown
- › Control panel
- › Lifting eyes integral to unit frame
- › Inlet particulate filter and maintenance indicator
- › On/off switch and final air pressure switch
- › Powder coated aluminum frame and cabinet enclosure
- › 316 stainless steel tubing
- › Stainless steel fittings, fixtures and fastening devices
- › 3rd party certified for operations at 55°C

DIESEL ENGINE DRIVEN MODELS

- › Name plated for operations at 55°C
- › Air-cooled diesel
- › Anti-vibration mounts for engine

AVAILABLE ACCESSORIES (FACTORY INSTALLED)

- › CO monitoring system
- › SECURUS - Electronic moisture monitoring for the purification system
- › H₂S monitoring system with audible alarm

SYSTEM FOOTPRINT

- DIMENSIONS L X W X H inches (mm)**
- › 61” x 37” x 41” (1549.4mm x 940mm x 1041.4mm)
- WEIGHT pounds (kg)**
- › 650 - 750 lb (295 - 340 kg)

TECHNICAL DATA

Model	Charging Rate ¹		Number of Stages	Motor		FAD ²	RPM	Purification System
	SCFM	L/MIN		HP	kW			
6000 PSIG (414 BAR)								
0320-D	13	368	4	18	13	10.8	1420	P2
0320-E	13	368	4	10	7.5	10.8	1420	P2

1) Based on recharging an 80 cubic foot tank from 500 to 3000 psig.
 2) Compressor capacity referenced to standard inlet conditions.
 D=Diesel engine driven. E3=Three phase electric, 208/230/460 VAC/60 Hz. Other voltages available on request. Dimensions and weight are approximate and are subject to change.

FIRE

FIRE

ENGINE DRIVEN

4- AND 5-STAGE HIGH-PRESSURE BREATHING AIR COMPRESSORS

The ENGINE DRIVEN compressor for recharging SCBA or SCUBA cylinders combines compressor, purification system, and engine drive. The frame's rugged design is specific to the requirements of the engine drive/compressor block assembly.

- › **PRESSURE:**
Up to 6000 PSIG (414 BAR)
- › **CHARGING RATE:**
13 to 60 SCFM
(368 to 1700 L/MIN)
- › **POWER:**
18 to 60 HP (13 to 45 kW)

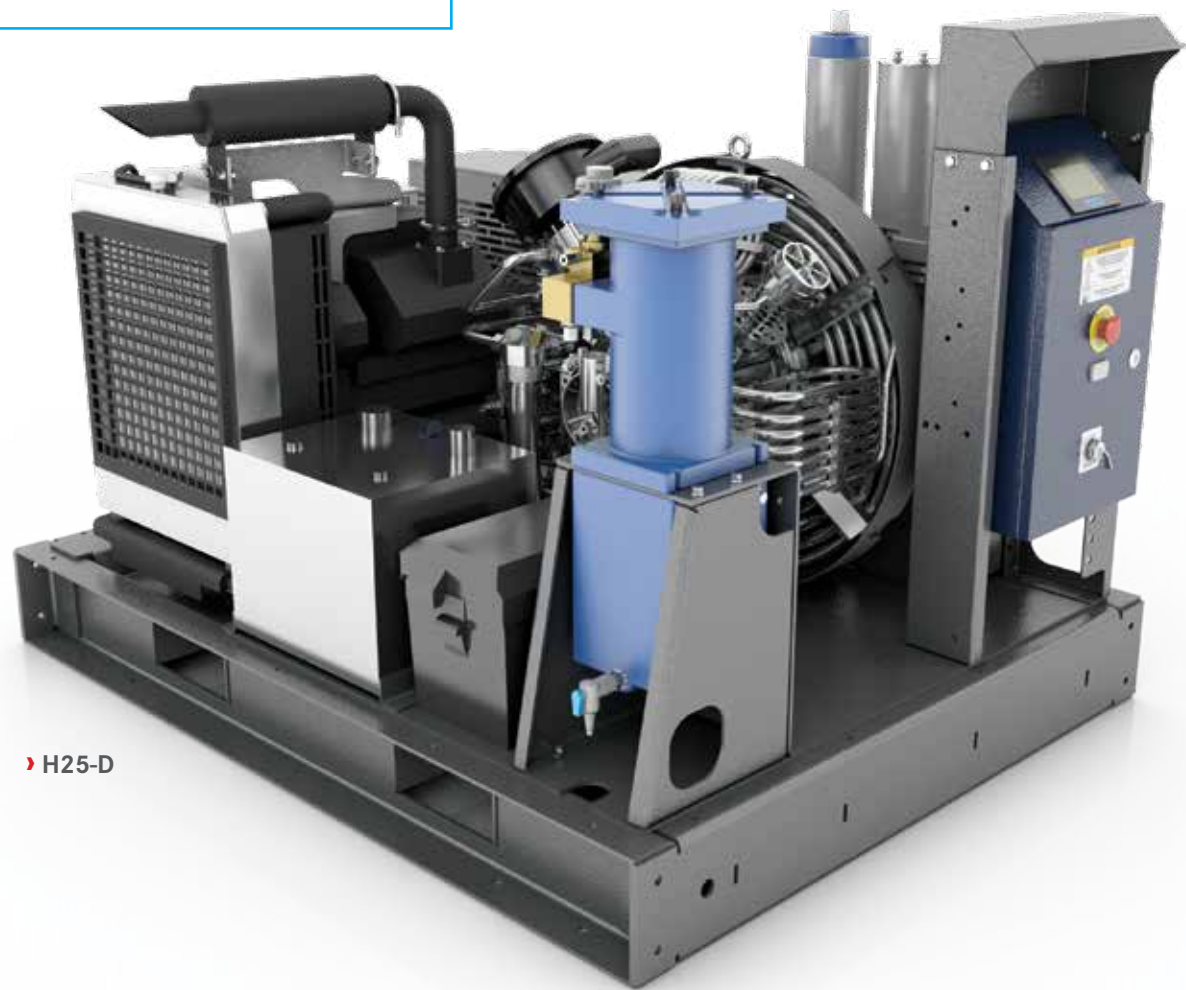

› H25-D

STANDARD SCOPE OF SUPPLY

- › BAUER breathing air purification system with B-SECURUS
- › BAUER PLC base controller with four line text display
- › NEMA 4 rated electrical enclosure with hourmeter
- › Compressor low oil pressure and high temperature safety shutdowns
- › Emergency stop push button
- › Automatic condensate drain system with non-corrosive condensate reservoir and integrated float sensor and automatic "Full" indication and compressor shutdown
- › Interstage pressure gauges
- › Electric start package including electric clutch and speed control solenoid
- › Closed loop water-cooled diesel

AVAILABLE ACCESSORIES (FACTORY INSTALLED)

- › BAUER Gas-Tek™ CO monitoring system
- › H₂S monitoring system

TECHNICAL DATA

Model	Charging Rate ¹		Number of Stages	Motor		FAD ²	RPM	Purification System
	SCFM	L/MIN		HP	kW			
5000 PSIG (345 BAR)								
K20-D	21	595	4	27	20	17.5	1300	P5 B-SECURUS
K26-D	26.4	748	4	27	20	22	1350	P5 B-SECURUS
K42-D	42	1190	4	44	33	35	1300	P10 B-SECURUS
K60-D	60	1700	4	60	45	50	1350	P12 B-SECURUS
6000 PSIG (414 BAR)								
H13-D	13	368	4	18	13	10.8	1420	P2 B-SECURUS
H18-D	18	510	4	27	20	15	1325	P5 B-SECURUS
H25-D	25.2	714	5	27	20	21	1300	P5 B-SECURUS
H35-D	35.9	1017	4	44	33	29.8	1200	P10 B-SECURUS

1) Based on recharging an 80 cubic foot tank from 500 to 3000 psig.
2) Compressor capacity referenced to standard inlet conditions.

SYSTEM FOOTPRINT

- H13-K26:**
DIMENSIONS L X W X H inches (mm)
› 63" x 49" x 46" (1600mm x 1245mm x 1168mm)
WEIGHT pounds (kg)
› 1300 - 3750 lb (590 - 1700 kg)
- H35-K42:**
DIMENSIONS L X W X H inches (mm)
› 95" x 52" x 49" (2413mm x 1320mm x 1245mm)
WEIGHT pounds (kg)
› 1300 - 3750 lb (590 - 1700 kg)
- K60:**
DIMENSIONS L X W X H inches (mm)
› 112" x 52" x 53" (2845mm x 1346mm x 1320mm)
WEIGHT pounds (kg)
› 1300 - 3750 lb (590 - 1700 kg)

FIRE

TCOM® TRAILER

4- AND 5-STAGE HIGH-PRESSURE MOBILE BREATHING AIR RECHARGING SYSTEMS

When your needs require a rugged trailer built for the fire service, rather than a cheap lightweight imitation, look to BAUER. Our TCOM® TRAILER designs are powered by a unique diesel/electric dual drive system. Each system is equipped with a 2 position containment fill station, an enclosed fill control panel, four ASME storage cylinders and integral SCBA storage for up to twelve SCBA cylinders all incorporated onto a heavy duty frame built by BAUER.

- › **PRESSURE:**
6000 PSIG (414 BAR)
- › **CHARGING RATE:**
13 to 25.2 SCFM (368 to 714 L/MIN)
- › **ELECTRIC MOTOR:**
10 to 20 HP (7.5 to 15 kW)
- › **DIESEL ENGINE (EPA Tier 4 Compliant):**
27 to 37 HP (20 to 27 kW)



› TCOM TRAILER

STANDARD SCOPE OF SUPPLY

- › BAUER breathing air purification system with B-SECURUS
- › BAUER PLC based controller with four line text display
- › NEMA 4 rated electrical enclosure with UL® listed control panel
- › Automatic condensate drain system with non-corrosive condensate reservoir and integrated float sensor and automatic “Full” indication and compressor shutdown
- › Four (4) 6000 PSIG ASME code stamped air cylinders
- › Integral SCBA storage for up to twelve (12) SCBA cylinders
- › NFPA 1901 2016 edition compliant 2 position containment fill station accommodates SCBA or SCUBA cylinders up to 31” overall length
- › Unique diesel/electrical dual drive system incorporating our exclusive automatic belt tensioning system
- › Powder coat paint for a hard durable finish
- › Hydraulic surge brakes with breakaway actuator
- › Four (4) bank dual function cascade controls with air direction valve
- › Formed structural steel frame designed and built by BAUER
- › Rolled shutter door protection for the operations panel and fill station
- › Refill port
- › BAUER Gas-Tek™ CO monitoring system with calibration kit
- › Lunette eye hitch

AVAILABLE ACCESSORIES (FACTORY INSTALLED)

- › **Option Package A** - Telescoping light mast with four (4) 500 watt fixtures, snorkel tube for compressor air inlet integrated with light mast and 7500 watt auxiliary generator
- › **Option Package B** - Spare tire and wheel chocks with fender well storage
- › **Option Package C** - 100 ft hose reel and interior lights
- › **Option Package D** - 2 5/16” ball hitch
- › **Option Package E** - 100 1/2” L x 5 1/2” H sign boards

TECHNICAL DATA

Model	Charging Rate ¹		Number of Stages	Motor/Engine		FAD ²	RPM	Purification System
	SCFM	L/MIN		HP	kW			
6000 PSIG (414 BAR)								
TCOM-13H	13	368	4	10 - 27	7.5 - 20	10.8	1420	P5 B-SECURUS
TCOM-25H	25.2	714	5	20 - 37	15 - 27	21	1300	P5 B-SECURUS

¹ Based on recharging an 80 cubic foot tank from 500 to 3000 psig.
² Compressor capacity referenced to standard inlet conditions.
 Image shown with additional accessories. Dimensions and weight are approximate and are subject to change.

SYSTEM FOOTPRINT

- DIMENSIONS L x W x H* inches (mm)**
- › 200” x 90” x 105”* (5080mm x 2286mm x 2267mm)
- WEIGHT pounds (kg)**
- › 8400 lb (3810 kg)
- * with optional light mast

FIRE

FIRE

DDTR25

Total solutions for law enforcement, security, facilities management, fire, rescue, clothing, marine craft and emergency/disaster response.

NAICS CODE #333912

Our aesthetically pleasing enclosure encompasses the compressor system from inclement weather and road debris and the heavy-duty frame provides a firm foundation for up to four air storage cylinders. The single axle design enhances mobility with most smaller vehicles.

- › **PRESSURE:**
6000 PSIG (345 BAR)
- › **CHARGING RATE:**
25.2 SCFM (714 L/MIN)
- › **POWER:**
DIESEL – 27 HP (20 kW)
ELECTRIC – 20 HP (15 kW)



› DDTR25

STANDARD SCOPE OF SUPPLY

- › Manufactured in compliance with the National Trailer Manufacturers Association (NATM) guidelines
- › NFPA 1901 2016 edition compliant 2 position containment fill station accommodates SCBA or SCUBA cylinders up to 31" overall length
- › Unique diesel/electric dual drive system incorporating our exclusive automatic belt tensioning system
- › High gloss powder coat paint for a hard durable finish
- › Hydraulic surge brakes with breakaway actuator
- › Bulk fill pneumatic logic
- › Four (4) DOT/UN air storage cylinders with bulk fill pneumatic logic
- › Formed structural steel frame designed and built by BAUER
- › Hypalon® type cover protection for the operations panel and fill station
- › Telescoping light mast with four 500 watt fixtures, snorkel tube for compressor air inlet integrated with light mast and 7500 watt auxillary generator
- › 7.5 kW belt driven generator

SYSTEM FOOTPRINT

- DIMENSIONS L x W x H inches (mm)**
- › 182" x 94.25" x 103" (4470mm x 2394mm x 2063.75mm)
- WEIGHT pounds (kg)**
- › 5500 lb (2495 kg)

AVAILABLE ACCESSORIES

- › Spare tire and wheel chocks with fender well storage
- › 100 ft. hose reel and interior lights
- › 2 5/6" ball hitch
- › ASME air storage in lieu of DOT/UN air storage

TECHNICAL DATA

Model	Charging Rate ¹		Number of Stages	Motor		FAD ²	RPM	Purification System		
	SCFM	L/MIN		Diesel	Electric					
	HP	kW	HP	kW						
6000 PSIG (414 BAR) NSN 4310-01-515-9940										
DDTR25	25.2	714	5	27	20	20	15	21.0	1300	P5-B-SECURUS

1) Based on recharging an 80 cubic foot tank from 500 to 3000 psig. 2) Compressor capacity referenced to standard inlet conditions. Dimensions and weight are approximate and are subject to change.
A. BAUER COMPRESSOR warranty includes parts and labor 12 Months from date of compressor start-up or 18 Months from date of shipment.
B. Spare parts consisting of normal wear and tear items; e.g., replacement cartridges, valve overhaul kits, gasket kits, belt, oil, inlet filter element, etc. are normal stock items at BAUER NORFOLK, BAUER SAN FRANCISCO, BAUER NORTHEAST and BAUER MIAMI.

TCOM LITE®

4- AND 5-STAGE HIGH-PRESSURE MOBILE BREATHING AIR RECHARGING SYSTEMS

If your needs do not require the amenities of the full-sized TCOM® look to the TCOM LITE®. Designed and manufactured by BAUER for the budget minded customer, the TCOM LITE® utilizes a multi-stage air-cooled compressor coupled to a water-cooled diesel engine (EPA Tier 4 compliant). Our aesthetically pleasing enclosure encompasses the compressor system from inclement weather and road debris and the heavy-duty frame provides a firm foundation for up to four air storage cylinders. The single axle design enhances mobility with most smaller vehicles.

- › **PRESSURE:**
6000 PSIG (414 BAR)
- › **CHARGING RATE:**
13 to 25.2 SCFM (368 to 714 L/MIN)
- › **POWER:**
18 to 27 HP (13.4 to 20 kW)



› TCOM LITE

STANDARD SCOPE OF SUPPLY

- › BAUER breathing air purification system with B-SECURUS
- › BAUER PLC based controller with four line text display
- › NEMA 4 rated electrical enclosure
- › Automatic condensate drain system with non-corrosive condensate reservoir and integrated float sensor and automatic “Full” indication and compressor shutdown
- › Two (2) 6000 PSIG UN code stamped air cylinders
- › NFPA 1901 2016 edition compliant 2 position containment fill station accommodates SCBA or SCUBA cylinders up to 31” overall length
- › Unique diesel drive system incorporating our exclusive automatic belt tensioning system
- › Powder coat paint for a hard durable finish
- › Hydraulic surge brakes with breakaway actuator
- › Four (4) bank dual function cascade controls with air direction valve
- › Formed structural steel frame designed and built by BAUER
- › Hypalon® type cover protection for the operations panel and fill station
- › Refill port
- › BAUER Gas-Tek™ CO monitoring system with calibration kit
- › 2” ball hitch

SYSTEM FOOTPRINT

- DIMENSIONS L x W x H inches (mm)**
- › 144” x 77” x 72” (3658mm x 1956mm x 1830mm)
- WEIGHT pounds (kg)**
- › 5400 lb (2450 kg)

AVAILABLE ACCESSORIES (FACTORY INSTALLED)

- › **Option Package A** - Spare tire with cover
- › **Option Package B** - 100 ft hose reel and interior lights
- › **Option Package C** - Lunette eye hitch
- › **Option Package D** - Two (2) additional 6000 PSIG UN code stamped air cylinders
- › **Option Package E** - Two (2) ASME cylinders in lieu of standard Two (2) UN cylinders

TECHNICAL DATA

Model	Charging Rate ¹		Number of Stages	Motor		FAD ²	RPM	Purification System
	SCFM	L/MIN		HP	kW			
6000 PSIG (414 BAR)								
TCL-13H	13	368	4	18	13.4	10.8	1420	P5 B-SECURUS
TCL-25H	25.2	714	5	27	20	21	1300	P5 B-SECURUS

1) Based on recharging an 80 cubic foot tank from 500 to 3000 psig.
 2) Compressor capacity referenced to standard inlet conditions.
 Image shown with additional accessories. Dimensions and weight are approximate and are subject to change.

FIRE

FIRE

TCOM-RC

IMPROVING EMERGENCY RESPONSE WHILE ENHANCING EFFICIENCY AND SAFETY

When emergency responders leave the station, they can never be certain about how long they will be away. Depending on various factors, they may need to refill their SCBAs back at the station later tonight, or they could be required to remain at the incident scene for an extended period.

To mitigate this uncertainty, many departments now use an Air and Light Trailer. This unit includes a diesel-powered breathing air compressor, stored air, one or more scene lights, a generator, storage for spare cylinders, and ideally, an enclosed area for protection from the elements.

The trailer serves as a work center, providing air, light, spare SCBAs, and a dry work area for hours or even weeks, depending on the situation at hand.



STANDARD SCOPE OF SUPPLY

- › Protected inside work area, with work bench, and an interior, dual lighting system (12/120 volt).
- › BAUER 6000psi compressor, either 13 cfm or 25 cfm (you choose).
- › CFS5.5-2Sx4x4 BAUER containment-style fill station, to meet NFPA 1901 standards. Fills two SCBAs at once, up to 5500psi
- › Four 6000psi UN/DOT cylinders, to hold 2036 cubic feet of stored air
- › CO Monitor, to meet NFPA 1989 standards
- › Custom deluxe trailer, 16-foot tandem-axle torsion bar suspension
- › Divider wall venter windows for easy access, maximum ventilation
- › 6 kW generator with diamond plate cover, tongue-mounted with power cord to run from the generator to the trailer
- › Built-in cabinets for storage, can carry 14 spare SCBA cylinders (SCBAs not included). Also a deluxe first aid kit
- › Two 12 volt rewind hose reels, one low pressure and one high pressure, each with 100 feet of hose. These come with a custom control panel
- › Two trailer-mounted 120 volt, 750 watt extendable lights and extension cords

AVAILABLE ACCESSORIES

- › Heater
- › Air conditioning
- › Outside awning, manual or power
- › Sinks and toilets
- › Built-in scene lights
- › Extra hose reels
- › Rear ramp door, instead of barn-doors
- › Rubber coin floor, instead of diamond plate
- › Pintle hitch, instead of ball
- › Electric tongue jack

SEASONS DON'T MATTER WHEN THE CALL COMES.

The TCOM-RC are built on a 16-foot tandem-axle trailer and are equipped with a rugged BAUER diesel compressor (either 13 or 25 cfm) and more than 2000 cubic feet of stored air. The trailer provides air, lights (powered by generator), a workbench, compressor, storage space for spare SCBAs, hazmat suits, or other items, and a lighted work area that is sheltered from the weather.

What's more, the trailer operates quietly at only 83 dBA, ensuring a comfortable working environment for personnel inside.



› In winter's cold, the dark of night or the heat of day, the TCOM-RC provides a warm, dry, well-lit, and organized work area.



Open the back, and you come to the heart of the TCOM-RC, the diesel-powered compressor. (13cfm or 25cfm)

You have easy access to the compressor block, to check the oil, monitor the gauges, or routine maintenance. The CO monitor (front room) fulfills NFPA 1989 regulations.

As the SCBAs are being filled from the 2000 cubic feet of stored air, the compressor is busy replenishing the storage system.

Air is pumped directly to the storage cylinders and fill station.



› The SCBA rack has spaces for 14 spare bottles. Cabinets can hold SCBA masks & parts, emergency provisions, first aid, Haz Mat, communication equipment, ropes and lines, and more. Recharge lights or phones, plug in the computer, do quick repairs.

FIRE

FIRE

TCOM-MS

CUSTOMIZED AFFORDABLE MOBILE BREATHING AIR TRAILER WITH GROUND LEVEL SCBA FILL OPERATION

STANDARD SCOPE OF SUPPLY

- › Premium 12' enclosed trailer tandem 3.5 axles, extended tongue, 2 5/16" coupler, white finished interior walls
- › 13 or 25 CFM BAUER diesel driven compressor unit with P5 Securus purifier and CO monitor
- › BAUER CFS5.5 2 with 4 bank Air Control Panel
- › 3 Diamond Door/Dover roll up doors
- › 4 exterior scene lights



AVAILABLE ACCESSORIES

- › 12 volt electrical package with interior light and fill station light, includes (2) Optima batteries, charging system (solar or 110 volt)
- › Regulated Hannah High Pressure spring rewind hose reel with 75' breathing air hose and fill adapter.
- › Carefree 3' x 6' power awning on rear of trailer over operator
- › 6 bottle (SCBA) drop in rack.

MOBILE PACKAGE

When your department requires the need for a mobile breathing air truck, look no further than BAUER. For 75 years, BAUER has been the industry leader in high pressure breathing air compressor systems. We start with critical components designed, engineered, and manufactured in our factories. Our sales & engineering staff work closely with your truck manufacturer of choice to ensure the entire system meets your department's critical needs. Your closest factory authorized BAUER Partner is brought into the equation to maximize customer satisfaction and support with the product after the truck has been delivered to you.

STANDARD SCOPE OF SUPPLY

- › Skid mounted BAUER multi-stage air-cooled compressor.
- › BAUER breathing air purification system with B-SECURUS electronic moisture monitoring system.
- › BAUER B-drain automatic condensate drain system with integral skid mounted collection reservoir
- › BAUER Gas-Tek™ CO monitoring system with calibration kit
- › BAUER PLC based controller with 7" color HMI touchscreen display
- › NEMA 4 rated electrical enclosure with UL® listed control panel
- › Single Phase & Three Phase Electrical Motor Voltage options
- › Soft start electronics to reduce initial start-up load on the truck mounted generator system
- › Compressor low oil pressure and high temperature safety shutdowns
- › Emergency stop push button
- › Stainless steel interconnecting piping
- › Air Storage Refill Port

BAUER CFS5.5® FILL STATIONS:

- › Designed & Tested to meet NFPA 1901 2016 Edition Standards
- › BAUER CFS5.5® fill stations were tested & passed a 5500 PSIG SCBA rupture with 110 cu ft cylinder
- › Our standard fill stations can be supplied in a single, two, or three position configurations
- › Dual two & three position fill stations are popular with larger fire departments
- › Can accommodate many sized steel & Aluminum Dive Tanks
- › Remote Mounted HMI Compressor Controls are integrated into our fill station control panels
- › Top or Side Mounted DUAL Function Cascade Control Panels
- › Air selector valve to select filling "From Compressor / Fill From Storage"
- › ABS Risers located in each fill position to ensure proper height of SCBA cylinder within Fill Station
- › Custom Fill Control Panels to include High Pressure & Low-Pressure Hose Reel Controls

AIR STORAGE OPTIONS:

- › UN DOT cylinders are rate to 6000 PSIG working pressure
- › 10 Year retest requirement for UN/ISO Cylinders.
- › ASME coded cylinders rated to 7000 PSIG working pressure (3:1 structural safety factor)
- › Safety Relief Valve installed on each ASME Cylinder along with moisture drain valve
- › All Cylinders are pre-piped with stainless steel tubing within compressor skid package
- › Cylinders can be shipped loose for custom installation within truck body

CUSTOM DESIGNED SYSTEM:

- › Up to 7,000 PSIG
- › 13 to 35 SCFM (368 to 1017 l/min) Charging Rate
- › 10 to 30HP (7.5 to 22kw)
- › Electric and diesel driven
- › UN and ASME air storage cylinders
- › Custom air flow control panels
- › NFPA 1901 Approved, 3rd Party Tested Containment Fill Stations
- › Proven performance with over 35 years of experience

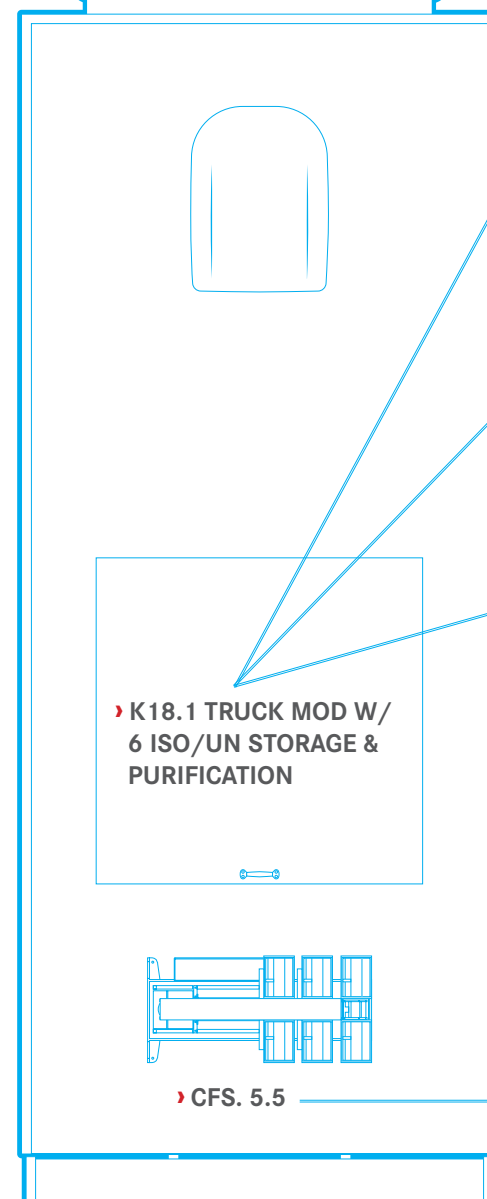
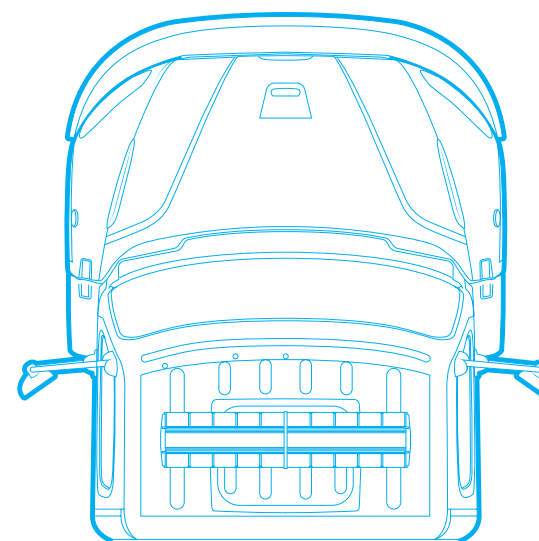

› FRONT VIEW



› SIDE VIEW



› AERIAL VIEW

› K18.1 TRUCK MOD W/
6 ISO/UN STORAGE &
PURIFICATION

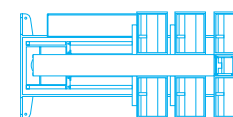

› CFS. 5.5



› CFS. 5.5



FIRE

FIRE

UNICUS® 4S

4- AND 5-STAGE ALL-IN-ONE HIGH-PRESSURE BREATHING AIR COMPRESSORS

A modern upgrade with the simplicity of analog controls; Aesthetically pleasing yet robust design found only in the UNICUS® 4S All-In-One platform. The system is available in either 5000 or 6000 PSIG with discharge capacities ranging from 13 SCFM charge rate to 26 SCFM charge rate. Unsurpassed maintenance accessibility abounds as we have provided all access doors with snap pin technology – pull the pin and lift the door; no hand tools are required. Should you require access to the back of the operations panel, no problem; we have your back, the panel tilts forward. All requisite panels are equipped with sound attenuated material. An integral rack built to accommodate four (4) storage cylinders is standard, along with the piping. Additionally, we provide two (2) ASME-coded air storage cylinders as a part of the standard scope of supply. If you want to dress your unit up in concert with the Fire Department theme, ask about our Fire Edition package. When your department needs the best All-In-One compressor system on the market today and backed by our global network of service partners, look to BAUER.

- › **PRESSURE:**
Up to 6000 PSIG (414 BAR)
- › **CHARGING RATE:**
13 to 26.4 SCFM (368 to 748 L/MIN)
- › **POWER:**
10 to 20 HP (7.5 to 15 kW)



UNICUS® 4S
FIRE EDITION
OPTIONAL FIRE EDITION PAINT SCHEME (SHOWN HERE)

STANDARD SCOPE OF SUPPLY

- › BAUER breathing air purification system with B-SECURUS
- › BAUER PLC based controller with 7" color HMI touchscreen display
- › NEMA 4 rated electrical enclosure with UL® listed control panel
- › Compressor low oil pressure and high temperature safety shutdowns
- › Emergency stop push button
- › Hinged cascade fill control panel with Lexan laminate air flow/fill schematic
- › Audible alarm on safety shutdowns
- › Inlet filter maintenance indicator
- › Automatic condensate drain system with non-corrosive condensate reservoir and integrated float sensor and automatic "Full" indication and compressor shutdown
- › Two (2) ASME code stamped air cylinders installed in an integral rack designed to hold four cylinders
- › Sound attenuating enclosure with 1/4" turn latches and lift-off type hinges
- › NFPA 1901 2016 edition compliant 3 position containment fill station accommodates SCBA or SCUBA cylinders up to 31" overall length

SYSTEM FOOTPRINT

UN 4S/13H-E1/E3 - UN 4S/26-E3:
DIMENSIONS L X W X H inches (mm)
 › 101" x 38" x 80" (2565mm x 965mm x 2032mm)
WEIGHT pounds (kg)
 › 4350 - 4550 lb (1973 - 2064 kg)

AVAILABLE ACCESSORIES (FACTORY INSTALLED)

- › BAUER Gas-Tek™ CO monitoring system
- › 100 ft high pressure cabinet enclosed hose reel
- › Panel mounted remote fill hose connection
- › Dual Fill/3 position
- › Tri Fill/3 position

TECHNICAL DATA

Model	Charging Rate ¹		Number of Stages	Motor		FAD ²	RPM	Purification System
	SCFM	L/MIN		HP	kW			
5000 PSIG (345 BAR)								
UN 4S/20-E3	21	595	4	15	11	17.5	1300	P5 B-SECURUS
UN 4S/26-E3	26.4	748	4	20	15	22	1350	P5 B-SECURUS
6000 PSIG (414 BAR)								
UN 4S/13H-E1/E3	13	368	4	10	7.5	10.8	1420	P2 B-SECURUS
UN 4S/18H-E3	18	510	4	15	11	15	1325	P5 B-SECURUS
UN 4S/25H-E3	25.2	714	5	20	15	21	1300	P5 B-SECURUS

1) Based on recharging an 80 cubic foot tank from 500 to 3000 psig.
 2) Compressor capacity referenced to standard inlet conditions.
 E1=Single phase electric, 230 VAC/60 Hz. E3=Three phase electric, 208/230/460 VAC/60 Hz. Other voltages available on request. Dimensions and weight are approximate and are subject to change.

OPTIONAL ACCESSORIES

Item	Description	Part Number
0001	BAUER Gas-Tek™ Electronic carbon monoxide monitor complete with calibration kit wired for alarm and shutdown. (calibration gas included)	GT/CO/III
0002	Each additional ASME 5000 PSIG cylinder with relief valve and mounting clamps	/CYL-9/5K
0003	Each additional ASME 6000 PSIG cylinder with relief valve and mounting clamps	/CYL-9/6K
0003	Panel mounted remote fill hose connection. Includes bulkhead fitting, adjustable regulator for up to 6000 PSIG service, gauge, isolation valve and quick connect/disconnect fitting (hose no included)	/RF/REG
0004	UN4 remote fill hose connection including adjustable regulator for up to 6000 PSIG service, gauge and isolation valve connected to a cabinet enclosed hose reel with 100 feet of hose rated for 6000 PSIG service	UN4/RF/REL-12
0005	DUAL-FILL, high/low, quick connect fill system (specify fill pressures)	DUAL-FILL/3 position
0006	TRI-FILL, high/low/SCUBA, quick connect fill system (specify fill pressures)	TRI-FILL/3 position
0007	Fire Edition paint scheme	

FIRE

OPTIONAL

INNOVATION AT YOUR FINGERTIPS



NEWLY REDESIGNED



- Motor ratings from 10 to 20 hp
- Discharge capacity from 13 to 26.4 scfm charge rate
- Industrial grade 15"-HMI/Interactive Touchscreen
- Operational pressures from 5000 to 7000 psig

INCREASED UPTIME QUICKER AND SECURE ACCESS

Our auto cascade system has replaced all operations panel-mounted valves and pressure gauges which help reduce human error when filling SCBA and SCUBA cylinders.

All system controls are within the panel-mounted HMI and include:

- › Air storage controls
- › Independent SCBA fill pressures
- › Independent SCBA fill speed
- › Automatic cascade control system rated for 7000 psi service
- › Secure and quicker way to log into the unit with a BAUER key fob
- › RFID Reader interface, automatically read & records the SCBA fill event in accordance with NFPA 1989 data collection requirements

Manual cascade bypass control comes standard to fill cylinders in case of a system power loss.

Optional Features:

- › Gas-Tek monitoring systems allow you to tailor the system to your departments specific requirements

UNICUS® 4i

4- AND 5-STAGE HIGH-PRESSURE BREATHING AIR COMPRESSORS

This game-changing filling station employs our state-of-the-art control system centered around a 15-inch HMI touch screen interface, which allows the operator to manage the entire system from the single-point touch screen. UNICUS®4i has several innovative optional features including BAUER Gas-Tek™ monitoring system, and RFID Reader.

- › **PRESSURE:**
Up to 6000 PSIG
(414 BAR)
- › **CHARGING RATE:**
13 to 26.4 SCFM
(368 to 748 L/MIN)
- › **POWER:**
10 to 20 HP
(7.5 to 15 kW)



› UNICUS® 4i



› UNICUS® 4i
(SHOWING INSIDE FRONT)



› UNICUS® 4i
(SHOWING INSIDE BACK)

STANDARD SCOPE OF SUPPLY

- › BAUER breathing air purification system with B-SECURUS
- › **BAUER 15-inch HMI touch-screen** interface
- › Solid state auto cascade system
- › Compressor low oil pressure and high temperature safety shutdowns
- › Emergency stop push button
- › Ergonomic system-operations panel
- › Ergonomically designed stainless steel fill adaptors with integral bleed valve
- › Automatic condensate drain system with non-corrosive condensate reservoir and integrated float sensor and automatic “Full” indication and compressor shutdown
- › Two (2) ASME code stamped air cylinders installed in an integral rack designed to hold four cylinders
- › NFPA 1901 2016 edition compliant 3 position containment fill station accommodates SCBA or SCUBA cylinders up to 31” overall length
- › RFID Reader which reads and records data from the RFID equipped cylinders

TECHNICAL DATA

Model	Charging Rate ¹		Number of Stages	Motor		FAD ²	Purification System
	SCFM	L/MIN		HP	kW		
5000 PSIG (345 BAR)							
UNICUS 4i -26 - E3	26.4	748	4	20	15	22	P5 B-SECURUS
UNICUS 4i -20 - E3	21	595	4	15	11	17.5	P5 B-SECURUS
6000 PSIG (414 BAR)							
UNICUS 4i -13- E1/E3	13	368	4	10	7.5	10.8	P2 B-SECURUS
UNICUS 4i -18- E3	18	510	4	15	11	15	P5 B-SECURUS
UNICUS 4i -25- E3	25.2	714	5	20	15	21	P5 B-SECURUS

¹ Based on recharging an 80 cubic foot tank from 500 to 3000 psig.
² Compressor capacity referenced to standard inlet conditions. Tolerance +/- 5%

OPTIONAL ACCESSORIES

Item	Description	Part Number
0001	BAUER Gas-Tek™ electronic carbon monoxide monitor complete with calibration kit wired for alarm and shutdown. (calibration gas included)	GT/CO/III
0002	Each additional ASME 5000 PSIG cylinder with relief valve and mounting clamps	/CYL-9/5K
0003	Each additional ASME 6000 PSIG cylinder with relief valve and mounting clamps	/CYL-9/6K
0004	Panel mounted remote fill hose connection. Includes bulkhead fitting, adjustable regulator for up to 6000 PSIG service, gauge, isolation valve and quick connect/disconnect fitting (hose no included)	/RF/REG
0005	UN4 remote fill hose connection including adjustable regulator for up to 6000 PSIG service, gauge and isolation valve connected to a cabinet enclosed hose reel with 100 feet of hose rated for 6000 PSIG service	UN4/RF/REL-12
0006	DUAL-FILL, high/low, quick connect fill system (specify fill pressures)	DUAL-FILL/3 position
0007	TRI-FILL, high/low/SCUBA, quick connect fill system (specify fill pressures)	TRI-FILL/3 position
0008	Fire Edition paint scheme	
FOR UNICUS® 4i ONLY		
0009	RFID SCBA Data Logging	RFID4i
0010	RFID DATA TAGS Each Kit includes 25-each tags	KIT-0557
0011	Cloud Storage for RFIDPro® SCBA cylinder management system. Price based upon number of SCBA's	TBD

SYSTEM FOOTPRINT

- DIMENSIONS L x W x H inches (mm)**
- › 101” x 38” x 80” (2565mm x 965mm x 2032mm)
- WEIGHT pounds (kg)**
- › 4350 - 4550 lb (1973 - 2064 kg)
- *Weights are based on a unit equipped with 4 ASMEs

AVAILABLE ACCESSORIES (FACTORY INSTALLED)

- › **BAUER Gas-Tek™** CO monitoring system
- › Hose reel for 100’ of high pressure breathing air hose
- › Reg/RF
- › Dual Fill/3 position
- › Tri Fill/3 position

FIRE

FIRE

OPEN DESIGNS

4- AND 5-STAGE HIGH-PRESSURE BREATHING AIR COMPRESSORS

Open packages in horizontal or vertical configurations combine compressor and air purification system in a space saving design. These compressors set the standard for larger capacity requirements.

- › **PRESSURE:**
Up to 6000 PSIG (414 BAR)
- › **CHARGING RATE:**
35.9 to 145 SCFM
(1017 to 4106 L/MIN)
- › **POWER:**
30 to 100 HP (22 to 75 kW)



› K60

STANDARD SCOPE OF SUPPLY

- › BAUER breathing air purification system
- › BAUER PLC based controller with 7" color HMI touchscreen display
- › NEMA 4 rated electrical enclosure with UL® listed control panel
- › Compressor low oil pressure and high temperature safety shutdowns
- › Emergency stop push button
- › Automatic condensate drain system with non-corrosive condensate reservoir and integrated float sensor and automatic "Full" indication and compressor shutdown
- › Beltguard designed to meet OSHA guidelines
- › Soft start and fuse disconnect
- › Interstage pressure gauges (locally mounted)

AVAILABLE ACCESSORIES (FACTORY INSTALLED)

- › BAUER Gas-Tek™ CO monitoring system
- › B-SECURUS - Electronic moisture monitoring for the purification system (K42V-E3 and K42-E3 only)
- › H₂S monitoring system with audible alarm

TECHNICAL DATA

Model	Charging Rate ¹		Number of Stages	Motor		FAD ²	RPM	Purification System
	SCFM	L/MIN		HP	kW			
5000 PSIG (345 BAR)								
K42V-E3 ³	42	1190	4	30	22	35	1300	P10
K42-E3 ³	42	1190	4	30	22	35	1300	P10
K60-E3	60	1700	4	40	30	50	1350	P12 B-SECURUS
K80-E3	80.4	2277	4	60	45	67	1225	P14 B-SECURUS
K145-E3	145	4106	4	100	75	121	1125	P14 B-SECURUS
6000 PSIG (414 BAR)								
H35V-E3	35.9	1017	4	30	22	29.8	1200	P10 B-SECURUS
H35-E3	35.9	1017	4	30	22	29.8	1200	P10 B-SECURUS
H80-E3	80.4	2277	5	60	45	67	1180	2x P10 B-SECURUS
H96-E3	96	2718	5	75	56	80	1100	2x P10 B-SECURUS

¹ Based on recharging an 80 cubic foot tank from 500 to 3000 psig.
² Compressor capacity referenced to standard inlet conditions.
³ SECURUS electronic moisture monitoring is not standard.
 E3=Three phase electric, 208/230/460 VAC/60 Hz. Other voltages available on request. KV/HV= VERTICAL. K/H= HORIZONTAL. Dimensions and weight are approximate and are subject to change.

SYSTEM FOOTPRINT

VERTICAL:

DIMENSIONS L X W X H inches (mm)

- › **K42V/H35V:** 65" x 42" x 75" (1667mm x 1051mm x 1905mm)

WEIGHT pounds (kg)

- › 1200 - 2800 lb (544 - 1270 kg)

HORIZONTAL:

DIMENSIONS L X W X H inches (mm)

- › **K42/H35:** 94" x 44" x 61" (2413mm x 1117mm x 1549.4mm)

- › **K60:** 94" x 44" x 61" (2337mm x 1117mm x 1549.4mm)

- › **K80/K145:** 116" x 84" x 67" (2946.4mm x 2134mm x 1702mm)

WEIGHT pounds (kg)

- › 1200 - 5000 lb (544 - 2268 kg)

FIRE

FIRE

PORTABLES

3-STAGE HIGH-PRESSURE BREATHING AIR COMPRESSORS

JUNIOR II and OCEANUS – include an air purification system and fill hose. These safe and reliable 3-stage compressors are designed for serious sport divers. Available in 1-phase 115/230 VAC and 3-phase 230/460 VAC electric motor or gasoline drives.

- › **PRESSURE:**
Up to 5000 PSIG (345 BAR)
- › **CHARGING RATE:**
2.9 to 4.9 SCFM
(82 to 139 L/MIN)
- › **POWER:**
2 to 6 HP (1.5 to 4.5 kW)



› ELECTRIC DRIVE



› GASOLINE DRIVE

STANDARD SCOPE OF SUPPLY

- › BAUER P0 breathing air purification system
- › Belt guard designed to meet OSHA guidelines
- › Inlet filter
- › Vibration isolators
- › High-temperature switch (G drives)
- › Five-foot fill hose assembly with SCUBA yoke, bleed valve and pressure gauge

OCEANUS MODELS (ADD TO ABOVE)

- › Sturdy, long lasting low pressure oil pump
- › Large oil sump allows shipboard inclination of 30°(20° G drive)
- › Capable of filling/maintaining up to a two cylinder 5000 PSIG UN storage system
- › Corrosion-resistant coolers and stainless steel frame

YACHTING PACKAGE (ADD TO ABOVE)

- › NEMA - 4 electrical box
- › Motor starter
- › Automatic condensate drain with muffler/separator and condensate reservoir
- › Pressure switch
- › Stainless steel fittings

TECHNICAL DATA

Model	Charging Rate ¹		Number of Stages	Motor		FAD ²	RPM	Purification System
	SCFM	L/MIN		HP	kW			
JUNIOR II 5000 PSIG (345 BAR)								
JRII-E1/115	2.9	82	3	2	1.5	2.5	1500	P0
JRII-E1	3.9	110	3	3	2.2	3.2	2100	P0
JRII-E3	3.9	110	3	3	2.2	3.2	2100	P0
JRII-GK	4.3	122	3	6	4.5	3.6	2300	P0
JUNIOR II YACHTING PACKAGE								
JRII-E1Y/115	2.9	82	3	2	1.5	2.5	1500	P0
JRII-E1Y	3.9	110	3	3	2.2	3.2	2100	P0
JRII-E3Y	3.9	110	3	3	2.2	3.2	2100	P0
OCEANUS 5000 PSIG (345 BAR)								
OCEANUS-E1	4.9	139	3	5	3.7	4.1	2150	P0
OCEANUS-E3	4.9	139	3	5	3.7	4.1	2150	P0
OCEANUS-GK	4.9	139	3	6	4.5	4.1	2150	P0
OCEANUS YACHTING PACKAGE								
OCEANUS-E1Y	4.9	139	3	5	3.7	4.1	2150	P0
OCEANUS-E3Y	4.9	139	3	5	3.7	4.1	2150	P0

Note: JRII is designed for filling an individual SCUBA or SCBA. It is neither designed nor intended for filling cascade storage systems of any kind. 1) Based on recharging an 80 cubic foot tank from 500 to 3000 psig. 2) Compressor capacity referenced to standard inlet conditions. E1/115= Single phase electric, 115 VAC/60 Hz. E1=Single phase electric, 230 VAC/60 Hz. E3=Three phase electric, 208/230/460 VAC/60 Hz. GK=Gasoline engine drive, KOHLER. Y=Yachting package. Dimensions and weight are approximate and are subject to change.

AVAILABLE ACCESSORIES (FACTORY INSTALLED)

- › Visual CO/Moisture monitor indicator
- › Final pressure switch for gasoline engine
- › Hourmeter/Tachometer (G drive)
- › B-Timer

SYSTEM FOOTPRINT

JUNIOR II:

DIMENSIONS L x W x H inches (mm)

- › JRII-E1/E3: 27" x 14" x 17" (686mm x 356mm x 432mm)
- › JRII-GK: 31" x 14" x 17" (787mm x 356mm x 432mm)
- › JRII-EY: 32" x 16" x 24" (813mm x 406.4mm x 610mm)
- › **WEIGHT pounds (kg)** 89 - 165 lb (40 - 75 kg)

OCEANUS:

DIMENSIONS L x W x H inches (mm)

- › OCEANUS-E1/E3: 27" x 17" x 17" (686mm x 432mm x 432mm)
- › OCEANUS-GK: 31" x 14" x 17" (787mm x 356mm x 432mm)
- › OCEANUS-EY: 32" x 20" x 17" (686mm x 432mm x 432mm)
- › **WEIGHT pounds (kg)** 96 - 135 lb (44 - 61 kg)

DIVE

DIVE

DMT II

3- AND 4-STAGE HIGH-PRESSURE BREATHING AIR COMPRESSORS

We reinvented our BAUER DIVE MATE® product family for 2023. Introducing the new DMT II package. A combination of a high-strength aluminum alloy tubular frame and a formed motor baseplate create a durable foundation for this lightweight, yet robust, package. We have increased the number of compressor offerings and motor drives to allow you to tailor the package to your specific requirements. We challenge you to find a more flexible package or greater variety of amenities: from 8.4 to 13.0 scfm charge rate, three (3) or four (4) stage BAUER compressor and BAUER purification. Electric motor, gasoline, or diesel engine drives allow you to select the mode of power best suited to your specific requirements. Furthermore, we even offer two (2) trim levels to allow you to select the appropriate package, to meet the buyer's needs.

- › **PRESSURE:**
Up to 6000 PSIG
(414 BAR)
- › **CHARGING RATE:**
8.4 to 13 SCFM
(170 to 368 L/MIN)
- › **POWER:**
7.5 to 14 HP
(5.6 to 10.4 kW)



› DMT II



STANDARD SCOPE OF SUPPLY

- › Available in three sizes 8, 10 & 13 SCFM charge rate
 - Choice of prime mover/drive
 - Electric motor, 1-phase or 3-phase
 - Gasoline engine (pull start)
 - Diesel engine (DMTII 08-DH & DMTII 10-DH, DMTII 13-DH, EPA Tier 4 Final)
- › Inlet filter
- › Stainless steel intercoolers and aftercooler
- › High temperature switch (except D drive)
- › Vibration isolators
- › P31 Purification for 5000 PSIG systems
- › P41 Purification for 6000 PSIG systems
- › Low oil pressure switch (electric drive)
- › Motor starter with NEMA 4 enclosure (electric drive units)
- › Hourmeter (electric and gasoline drive) or Vibration type (diesel drive)
- › Final pressure switch (electric & gasoline drive)
- › Visual CO/moisture indicator
- › Tubular aluminum frame

DMT II ELITE (ADD TO ABOVE)

- › Interstage gauges
- › Automatic condensate drain
- › Electric start and low oil pressure switch for gasoline and diesel drive units.

AVAILABLE ACCESSORIES (DEALER/CUSTOMER INSTALLED)

- › Wheel kit
- › Riser kit

SYSTEM FOOTPRINT

DIMENSIONS L X W X H inches (mm)

- › 48" x 33" x 31" (1219mm x 819mm x 711mm)*

WEIGHT pounds (kg)

- › 350 - 450 lb (136 - 204 kg)

* Base Model

AVAILABLE ACCESSORIES (FACTORY INSTALLED)

- › B-Timer (P31)

TECHNICAL DATA

Model	Charging Rate ¹		Number of Stages	Motor		FAD ²	Purification System
	SCFM	L/MIN		HP	kW		
5000 PSIG (345 BAR)							
DMTII 08-E1/E3	8.4	238	3	7.5	5.6	7	P31
DMTII 08-GK	8.4	238	3	14	10.4	7	P31
DMTII 08-DH	8.4	238	3	8.3	6.2	7	P31
6000 PSIG (414 BAR)							
DMTII 10-E1/E3	9.7	275	4	7.5	5.6	8.1	P41
DMTII 10-GK	9.7	275	4	14	10.4	8.1	P41
DMTII 10-DH	9.7	275	4	8.3	6.2	8.1	P41
DMTII 13-E1/E3	13	368	4	10	7.5	10.8	P41
DMTII 13-GK	13	368	4	14	10.4	10.8	P41
DMTII 13-DH	13	368	4	14	10.4	10.8	P41

1) Based on recharging an 80 cubic foot tank from 500 to 3000 psig.
 2) Compressor capacity referenced to standard inlet conditions.
 E1= Single phase electric, 230 VAC/60 Hz. E3=Three phase electric, 208/230/460 VAC/60 Hz. Other voltages available on request. GK=Gasoline engine drive, KOHLER DH=Diesel engine drive, Hatz.
 Dimensions and weight are approximate and are subject to change.

CFS5.5®

CONTAINMENT FILL STATIONS FOR AIR AND OXYGEN

Choose from a complete line of containment fill stations suitable for SCBA or SCUBA cylinders. Whether you need a 3, 2 or single-position fill station, be assured each model was proof tested by an independent lab to safely contain fragments of a ruptured 5500 PSIG 110 cu. ft. SCBA cylinder at maximum operating pressure in accordance with the 2016 Edition of NFPA 1901 and or 1989. Ask about our custom options to tailor a model to your specific requirements.

› **FILL POSITIONS:**

- One, two, or three
- Mobile or Stationary

› **CUSTOM DESIGNED SYSTEM:**

- Dual function cascade controls (2 or 3 position)
- Remote fill outlets



› CFS5.5-3S



› **CFS5.5®-3S/Package A**
Shown with Cascade controls and regulated remote fill

STANDARD SCOPE OF SUPPLY

- › Complete with cylinder scuff guard, SCBA fill connection, fill hose and bleed valve
- › Fill control panel with adjustable regulator, relief valve, manual control valve and pressure gauge for each fill position (“S” version only)
- › CFS5.5® “M” versions designed for use with remote air distribution panel
- › Mounting base is standard on “S” version and optional on “M” version
- › Convenient door handle actuation
- › Bottom venting
- › Reduced footprint



› CFS5.5®-1S



› CFS5.5®-2S



› CFS5.5®-2S/ Package A



› OXY-2S*

SYSTEM FOOTPRINT

CFS5.5®-1S & OXY-1S:

DIMENSIONS L X W X H inches (mm)

- › 18” x 21” x 55” (457mm x 533mm x 1397mm)

WEIGHT pounds (kg)

- › 433 lb (196 kg)

CFS5.5®-1M & OXY-1M:

DIMENSIONS L X W X H inches (mm)

- › 18” x 21” x 39” (457mm x 533mm x 990mm)

WEIGHT pounds (kg)

- › 360 lb (163 kg)

CFS5.5®-2S & OXY-2S:

DIMENSIONS L X W X H inches (mm)

- › 30” x 21” x 57” (762mm x 533mm x 1448mm)

WEIGHT pounds (kg)

- › 670 lb (304 kg)

CFS5.5®-2M & OXY-2M:

DIMENSIONS L X W X H inches (mm)

- › 30” x 21” x 39” (762mm x 533mm x 990mm)

WEIGHT pounds (kg)

- › 550 lb (249 kg)

CFS5.5®-3S:

DIMENSIONS L X W X H inches (mm)

- › 41” x 21” x 57” (1041mm x 533mm x 1448mm)

WEIGHT pounds (kg)

- › 905 lb (411 kg)

CFS5.5®-3M:

DIMENSIONS L X W X H inches (mm)

- › 41” x 21” x 39” (1041mm x 533mm x 990mm)

WEIGHT pounds (kg)

- › 740 lb (336 kg)

*All components in Oxygen stream are Oxygen cleaned in compliance with A.S.T.M. Standard G-93. Dimensions and weight are approximate and are subject to change. Images shown with additional accessories.

AIR STORAGE

UN AND ASME STORAGE SYSTEMS

BAUER high pressure air storage systems meet the code requirements of both the United Nations Model Regulations and the American Society of Mechanical Engineers. Storage cylinders and storage systems are offered for 5000, 6000 and 7000 PSIG applications. Optional mounting racks are available.

- › **PRESSURE:**
5000 PSIG (345 BAR)
6000 PSIG (414 BAR)
7000 PSIG (476 BAR)
- › **CONFIGURATION:**
Vertical
Horizontal
- › **STORAGE:**
Bulk
Bank



› UN STORAGE



› ASME STORAGE

REFERENCE ASY-0759 FOR VERTICAL CONFIGURATIONS
AND ASY-0758 FOR HORIZONTAL CONFIGURATIONS

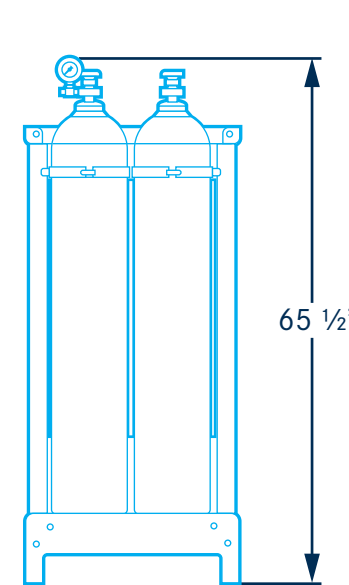

› UN STORAGE

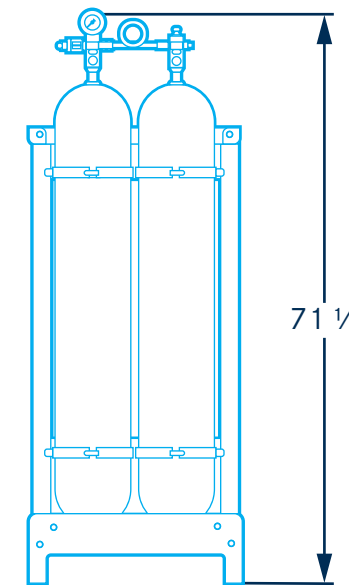

› ASME STORAGE

Model	Weight 2-Cylinder Rack	
	lbs	kg
UN 5000	475	215
UN 6000	525	238
ASME	935	424

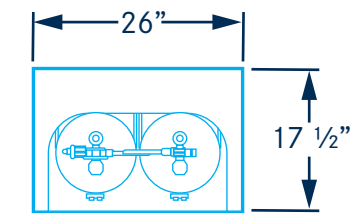

TYPICAL SYSTEMS SHOWN BELOW

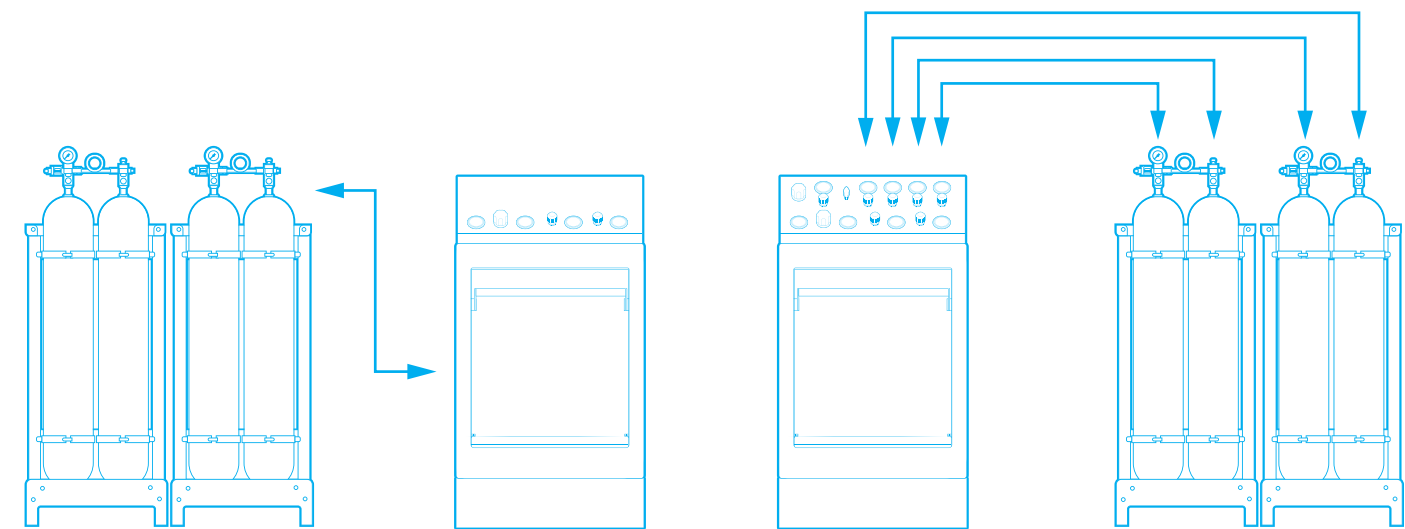

› **BULK STORAGE SYSTEM**
ASME 4/BANK

› **FOUR BANK CASCADE STORAGE SYSTEM**
ASME 4/BANK/1-1-1-1

AUTO CASCADE

SAFE AND AUTOMATIC CASCADE SCBA FILLING

The world leader in high pressure breathing air is proud to offer the premier method of automatically cascading your air storage system. The system utilizes our patent pending manifold block with integral valve bodies. Couple this with a commercially available PLC controller and you have the simplest cascade system available in the marketplace today.

- › **FOUR TO ONE SAFETY FACTORS:**
All components are manufactured for 7000 PSIG service
- › **12 OR 115 VOLT OPERATED:**
Simply specify at the time of order
- › **MANIFOLD INTEGRATION:**
On any manufacturers cascade system



STANDARD SCOPE OF SUPPLY

- › Corrosion resistant high strength aluminum alloy manifold block
- › Programmable Logic Controller for simplistic operation and heightened accuracy
- › No adjustable shuttle valves
- › HMI indication as to which cascade cylinder is being utilized
- › The system can be utilized on either stationary or mobile cascade systems
- › A preset pressure bias of 300 PSIG can be adjusted to allow for quicker switch over time from one bank to another
- › Pressure sensing by transducers rather than sequential valves, provides greater accuracy without leaks or pressure drift
- › A bypass circuit is incorporated into the system allowing the storage system to be bypassed. This enhancement allows for more effective hose reel operation or possibly filling a mobile cascade system from a stationary system

SAFETY AND ADDED VALUE

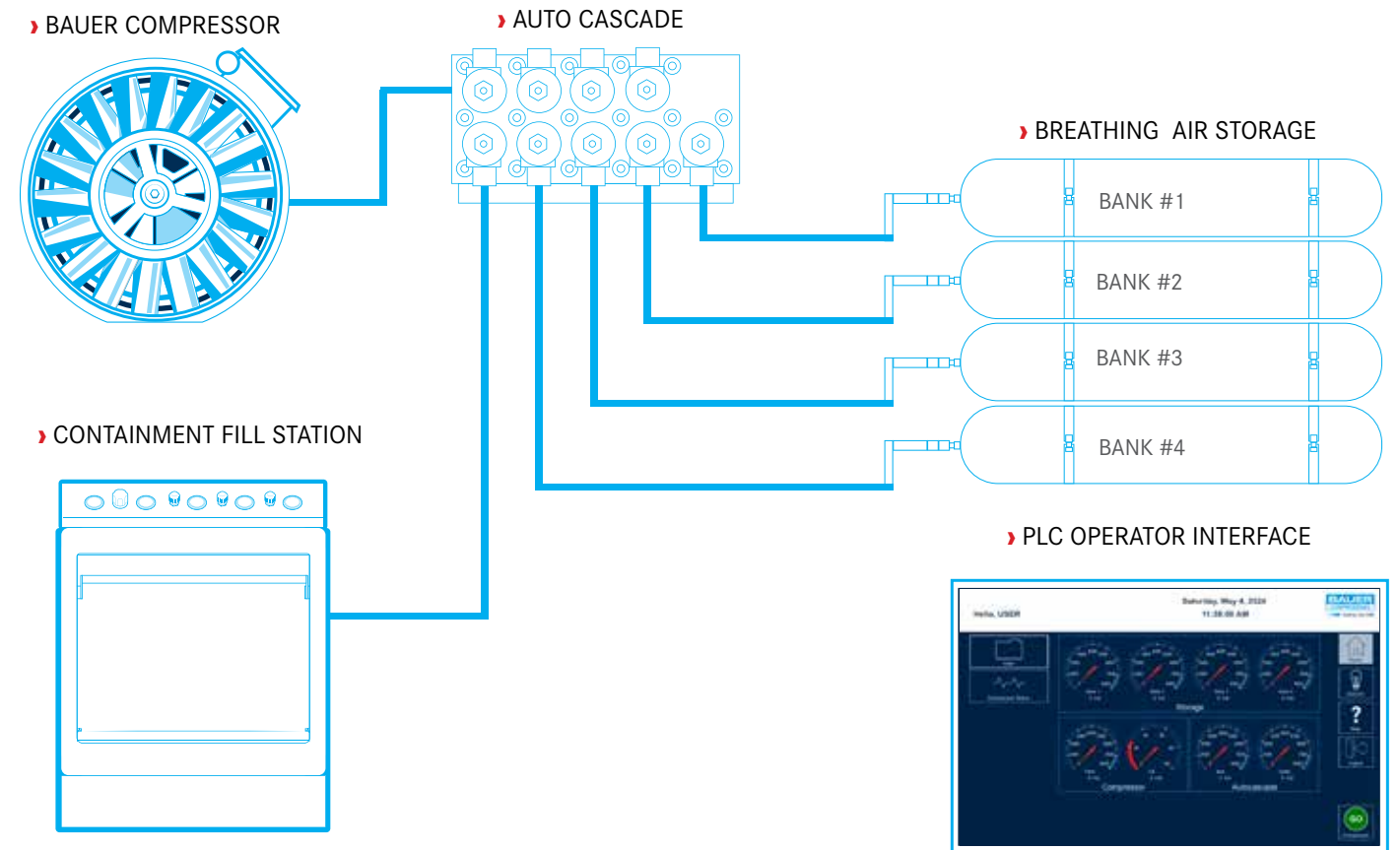

A

A

HOSE REELS

ORGANIZATION FOR CONVENIENT REMOTE SYSTEM AIR FILLING

BAUER offers an optional hose reel to keep fill lines organized, eliminating clutter and potential trip hazards. Available in 75' or 100' hose lengths, no matter the layout of your facility or the configuration of your setup, your remote filling needs are covered. Our durable, long-lasting filling hoses are rated for the high pressures of SCBA filling, and the reel itself has high-quality construction, with guide rollers and a ball stop for convenience. Users can choose standard reels without controls or opt for full controls with a regulator, line valve, and inlet/outlet gauges.

- › **AVAILABLE WITH FULL CONTROLS:**
Inlet/outlet gauges, regulator, line valve
- › **75' or 100' HOSE LINE CAPACITY:**
With guide rollers and ball stop
- › **CUSTOMIZE FILLING OPTIONS:**
Remote use for Rescue/Tower Ladder air systems



› **STANDARD REEL**

› **FULL CONTROL REEL**

B-DETECTION

CONTINUOUS AIR QUALITY MONITORING

B-DETECTION PLUS monitors the quality of the breathing air you produce: measuring CO, CO₂, O₂ as standard and offering options for absolute humidity and residual oil (VOS)¹. Automatic, continuous and ultra-reliable.

The B-CONTROL compressor control unit enables you to monitor compliance with the values of the NFPA and DIN EN Breathing Air Standard at all times¹. If limit values are exceeded, the control unit displays a visual warning and shuts down the system before contaminated air can pass into the cylinders being filled.

Automatic shutdown if flow is blocked: To ensure continuous flow of air and guarantee correct measurement values, an integrated flow monitor automatically shuts down the compressor if the flow is interrupted or reduced, e.g. caused by piping kinks or blocked filter elements.

B-DETECTION FOR INTEGRATION INTO COMPRESSOR SYSTEMS

If desired, B-DETECTION can be integrated into your new control unit at the factory². To ensure optimum operating conditions for the sensors and maximize service life, B-DETECTION is installed in the cold air flow. Both the gas measurement system itself and the gas extraction unit that regulates the inlet pressure of the B-DETECTION PLUS are integrated into the compressor.

A single control unit for all components: So convenient - simply read off the current air quality values from your compressor control unit. You can also make any changes to your B-DETECTION PLUS settings there too.



B-DETECTION FOR RETROFITTING AND FURTHER COMPRESSOR SYSTEMS

The new gas measurement system is also available as a standalone model, B-DETECTION PLUS s. Offering the same range of functions, it is designed for separate wall mounting and can be used with further BAUER systems or retrofitted to existing systems.

Air quality levels are displayed on the BAUER CONNECT control unit of the standalone gas measurement system, which can also log measurement values, The B-DETECTION can also automatically shut down the compressor system contamination levels rise. Measurement values can be transmitted to the control unit, depending on the model..

BAUER CRC™ CHARGE RATE CONTROL

The BAUER Charge Rate Controller (CRC™) has been designed to automatically fill SCBA and SCUBA cylinders to their maximum allowable pressure as well as allow the operator performing the fill to control the charge rate avoiding hot fills and maximize stored air in the cylinders.



BENEFITS:

- › Reduce complexity - No more fidgeting with dials; the BAUER CRC™ automatically charges SCBA and SCUBA cylinders to the right pressure with the push of a button.
- › Avoid “hot fills”, maximize stored air - Filling SCBA or SCUBA cylinders too fast will decrease the stored air in the cylinder when the cylinder cools down after charging. The BAUER CRC™ avoids this by controlling the rate of charge.
- › Allows for three different charge rate settings with the push of a button
- › Can be adapted to existing BAUER compressor systems

OPERATION:

The BAUER CRC™ makes automatic filling of an SCBA or SCUBA cylinder easy with these three steps:

- › **Step 1:** From the main menu select the SCBA or SCUBA cylinder you wish to fill
- › **Step 2:** Select the desired charge rate from one of three options: Normal, Hot Fill or Custom
- › **Step 3:** Press “Start Fill”

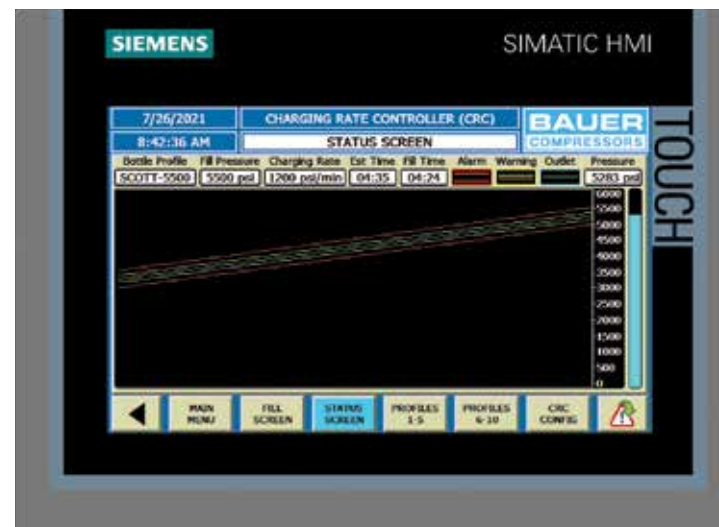
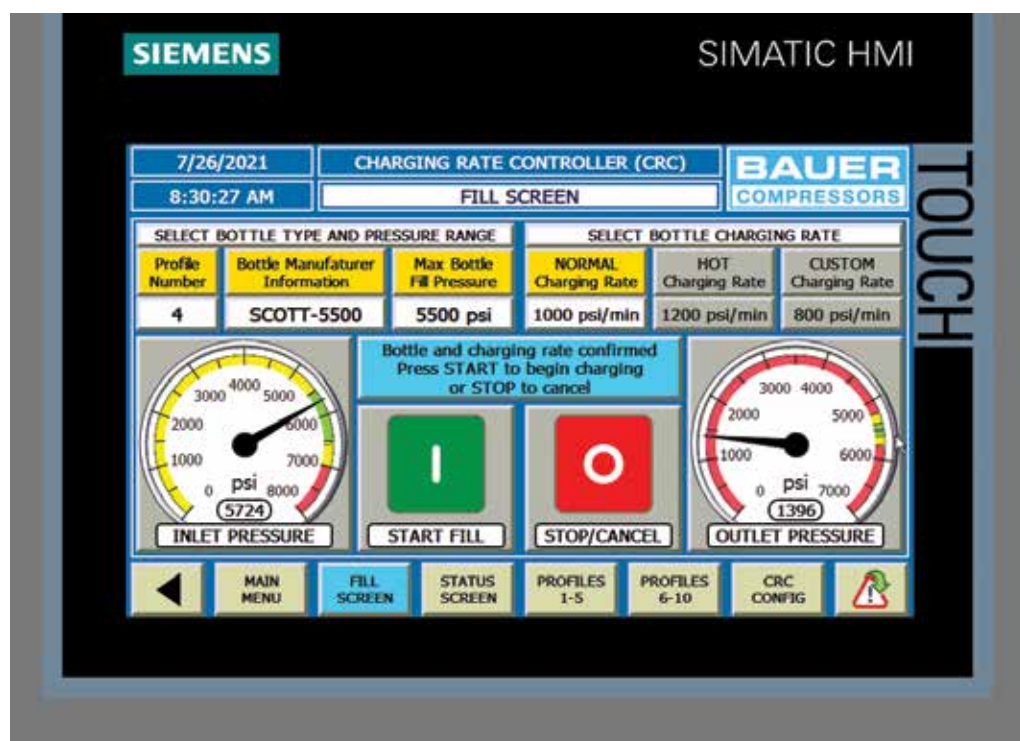

STATUS SCREEN

Indicates Fill Rate & Cylinder Pressure

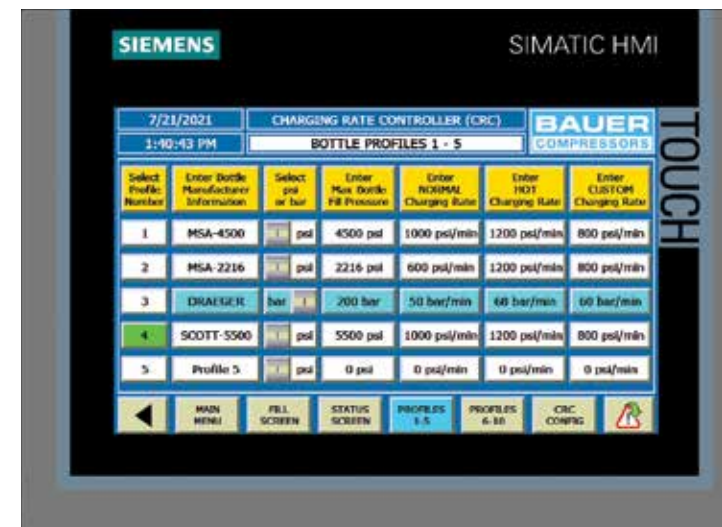

CUSTOMIZABLE CYLINDER PROFILE SCREEN

FEATURES

- › PLC controlled with color HMI touchscreen
- › Select from up to 10 customizable SCBA or SCUBA cylinder configurations, each with their own name designation and max fill pressure
- › Select from up to three customizable charge rates
- › Fill rate is accurately controlled with BAUER’s proprietary technology
- › Compatible with cascade storage and containment fill stations
- › Field retrofit to existing BAUER compressor systems
- › Easy installation: wall mountable; requires only two high pressure hose connections and plug-in 110V power

SYSTEM SPECIFICATIONS

DIMENSIONS L x W x H

- › 7.5” x 21” x 26” (190.5mm x 533.4mm x 660.4mm)

WEIGHT

- › 40 lbs (18 kg)

MAXIMUM INLET PRESSURE

- › 6000 PSIG (414 BAR)

MAXIMUM FILL PRESSURE

- › 5500 PSIG (379 BAR)

HIGH-PRESSURE CONTROL PRESSURE PORT:

- › 1/4” NPT female

HIGH-PRESSURE FILLING INLET PORT:

- › 1/4” NPT female

HIGH-PRESSURE FILLING OUTLET PORT:

- › 1/4” NPT female

PURIFICATION



HIGH-PRESSURE BREATHING AIR PURIFICATION FOR BAUER SYSTEMS

BAUER Air Purification Systems purify high-pressure air to a quality that meets or exceeds the requirements of CGA Pamphlet G-7, Compressed Air for Human Respiration, ANSI/CGA G-7.1, Commodity Specification for Air, Grade E, and all other recognized standards for breathing air. Recognizing that filtration systems are unfortunately one of the most often overlooked systems, BAUER always utilizes the highest quality components to protect the system operator. Every BAUER high-pressure breathing air purification system final separator, from the P41 to the P10, is manufactured from high-strength chromium steel alloy, which never requires hydrotesting! All BAUER 6,000 PSI purification chambers are manufactured from a high-strength aluminum alloy that satisfies the 4:1 structural safety factor requirements specified within NFPA-1901 and NFPA-1989 codes. Our purification systems can also be retrofitted for integration into most brands of high-pressure breathing air compressor systems manufactured today!

› **WORLDWIDE LEADER:**

- Compressors
- Purification and filtration

› **ANODIZED ALUMINUM FILTER CARTRIDGE:**

- Filter cartridge end caps are machine crimped
- Eliminating glues/friction welding

› **ANODIZED ALUMINUM FILTER CHAMBERS:**

Each chamber and plug assembly are serialized to assure system traceability



› **SECURUS**
Images shown may have optional features.



› B-TIMER



› P0 TRIPLEX



› P31 SUPER TRIPLEX

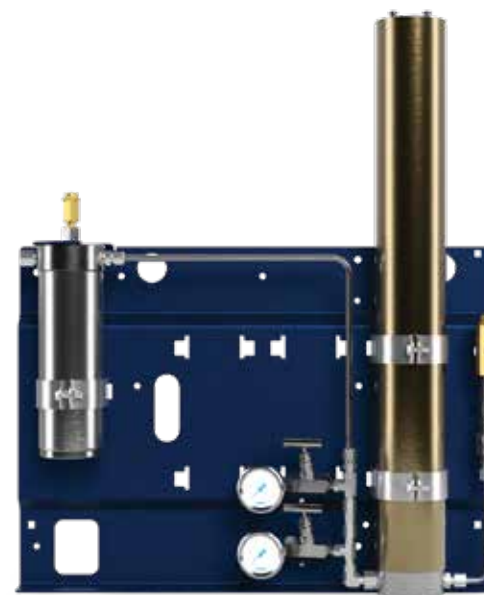

› P2

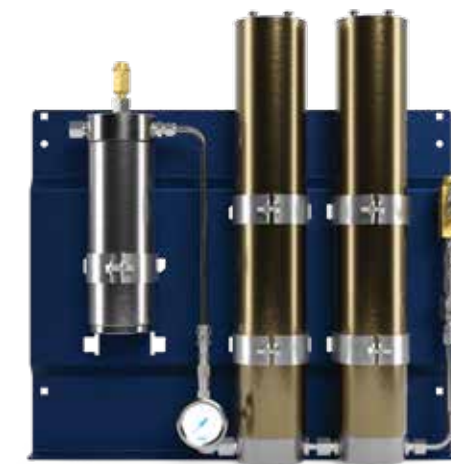

› P42

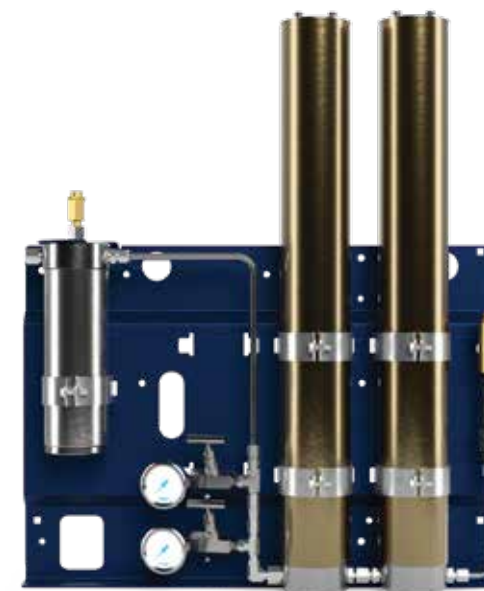

› P5

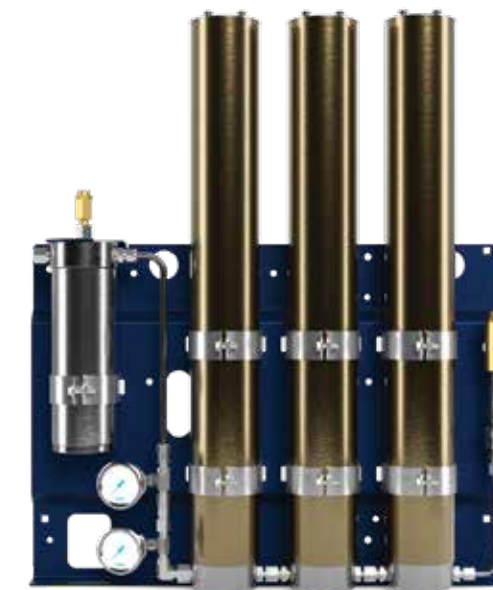

› P10

BAUER *B-VIRUS FREE®

*THE B-VIRUS FREE™ FILTER ELIMINATES UP TO 99.9% OF CORONAVIRUSES, BACTERIA AND CERTAIN MOLDS FROM INTAKE AIR.

COMPRESSOR INTAKE AIR FILTRATION SYSTEM FOR SAFETY WITHOUT COMPROMISE

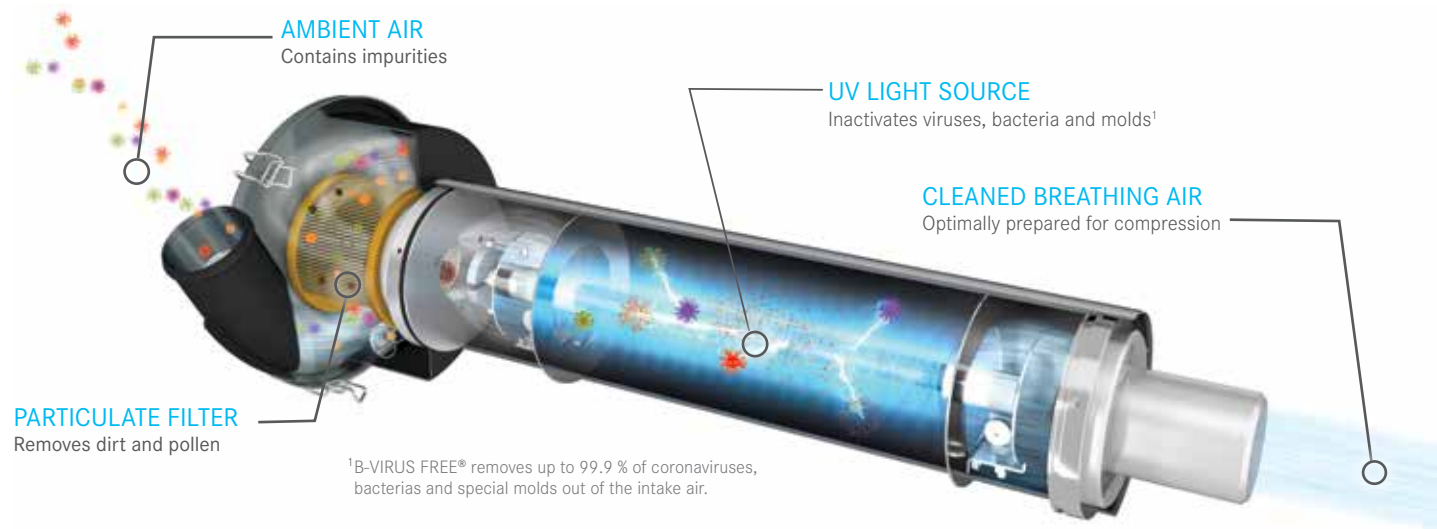

PROTECTING YOUR HEALTH IS OUR NUMBER ONE PRIORITY

Science has shown that viruses and bacteria can spread rapidly over great distances through aerosol dispersion. Mixed in the ambient air, they can pass through any commercially available standard air purification system which is part of the typical breathing air compressor system. Even the high temperatures and pressures of a typical high- pressure breathing air compressor have little effect on viruses and bacteria because of their short- duration exposure to the process.

The new BAUER B-VIRUS FREE® breathing air filtration system (patent-pending) inactivates up to 99.9% of viruses including coronaviruses, bacteria, and molds at the air intake section of your BAUER breathing-air-compressor. The system is designed to protect firefighters, divers, hazardous-location-workers, military personnel, or anyone who breathes compressed breathing air through SCBA or SCUBA cylinders. EPA Est. No. 100175-VA-1



INTAKE PARTICULATE FILTER

Underpressure in the compressor draws in air through the intake filter opening. Normal dust particles and even pollen are removed from the air by the intake filter.



CONTROL AND DISPLAY

The control unit of the B-VIRUS FREE® protective filter system monitors functions and controls the UV light source. Operational status information is provided by visual (LED) and acoustic signals.



CONNECTION TO COMPRESSOR

The B-VIRUS FREE® protective filter system is connected to a specially sealed intake hose, which eliminates any potential new contamination from leaks between the protective filter and the compressor block.



UV PURIFICATION

The specially deigned UV light source emits high-energy UVC radiation that destroys the molecular bonds in the DNA of bacteria and molds and in the RNA of viruses. This prevents the pathogens from reproducing.



OZONE FREE

The B-VIRUS FREE® filter system produces no harmful ozone.

EFFECTIVE INACTIVATION OF CORONA VIRUSES, BACTERIA AND MOLDS

Free of chemicals and ozone, the B-VIRUS FREE® system uses a specially designed UVC light source to destroy the pathogens before the intake air section of the compressor. The highly effective wavelength in the B-VIRUS FREE® system is absorbed by the pathogens' DNA, where the photons destroy the bonds between the DNA strands of the viruses, bacteria, and mold spores and effectively prevent them from reproducing.

LOW MAINTENANCE, LOW OPERATING COSTS

The B-VIRUS FREE® compressor intake air filter system has long maintenance intervals to keep operating costs down. The filter does not require replaceable filter cartridges. The UVC light source has an extremely long service life of approx. 2,000 hours and is simple to replace.

EASY INTEGRATION INTO YOUR BAUER COMPRESSOR SYSTEM

The B-VIRUS FREE® compressor air intake filter system can be ordered for any new model BAUER VERTECON®, VERTICUS®, BAUER LEGACY®, and UNICUS® 4S & 4i breathing air compressor systems. B-VIRUS FREE® will also be available as a retrofit kit for older BAUER breathing air compressor systems.



VERTECON®
The B-VIRUS FREE® system shown integrated into the BAUER VERTECON® Breathing Air Compressor System

TECHNICAL DATA

B-VIRUS FREE®	
	Values
APPLICATION	
Pressure Range	Atmospheric Intake Air
Compressor Charge Rate Range	3.5-30 scfm (100 - 850 l/min)
FUNCTIONS	
Required Warm-Up Time	60 secs
Visual Indicators	Warm-up/Normal/Fault
Audible Signal	in case of fault
TECHNICAL DATA	
Permissible operating temperature range	+41°F(+5°C) to +105°F (+40°C)
Operating voltage	110/220 volts, ac, single phase (60/50Hz)
UV lamp service life	2,000 hrs or every 2 years
Weight filter unit	approx. 17.5 lbs (7kg)
Weight control box	approx. 12.5 lbs (5kg)
Dimensions W x D x H	36x10x18 in (905x250x450 mm)

The B-VIRUS FREE® filter eliminates up to 99.9% of coronaviruses, bacteria and certain molds from intake air.

BAUER RFIDPro®

The BAUER RFIDPro SCBA Cylinder Management System is a subscription service which provides Fire Departments with a system designed to improve the safety of the SCBA cylinder filling process as well as provide compliance with all of the governmental reporting requirements such as NFPA-1989 and OSHA-1910.134 associated with the cylinder management process.

The system also serves as a powerful inventory management tool, helping fire departments identify the status and track the location of their entire SCBA cylinder inventory in real-time.

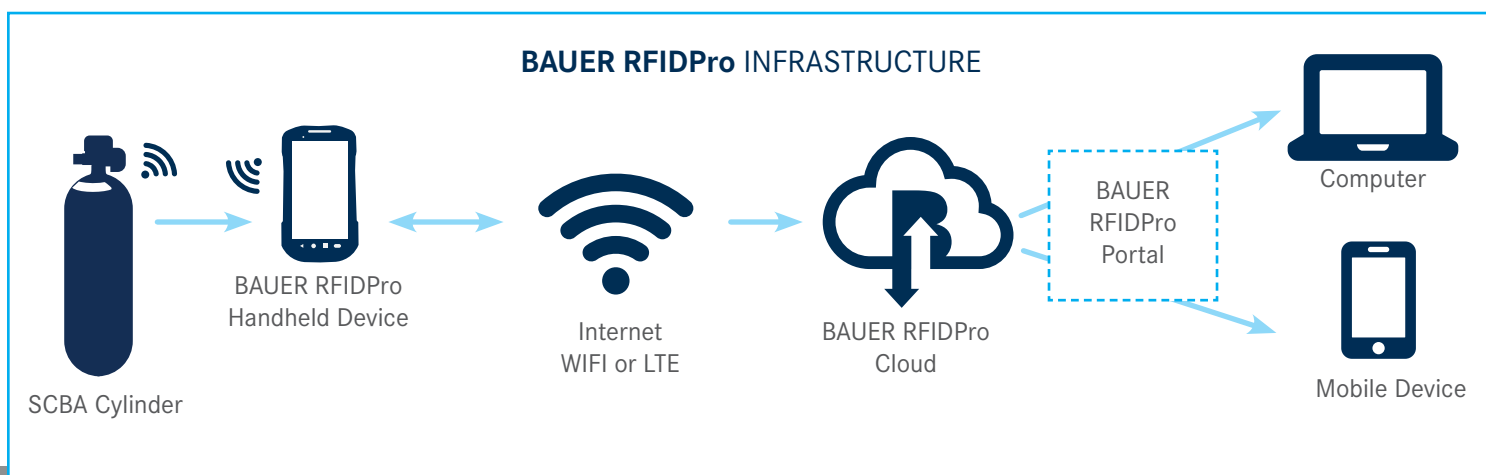

STANDARD FUNCTIONALITY

BAUER RFIDPro HANDHELD DEVICE

- › Allows new SCBA cylinder registration through the BAUER RFIDPro handheld device or directly through the BAUER RFIDPro customer portal
- › Guides the cylinder fill operator through the entire SCBA cylinder fill process to assure that all required steps are followed in sequence and performed in a safe manner
- › Alerts the cylinder fill operator if an SCBA cylinder is expired, past due on hydro testing or inactive due to failed inspection.
- › Sends push and e-mail notifications to responsible fire department personnel in advance of cylinder expiration or hydro past due date as well as when a cylinder fails inspections
- › Automatically logs every aspect of the SCBA cylinder fill process and documents all required NFPA-1989 criteria including time and date stamp, operator ID, cylinder inspection process and recorded fill pressure
- › Allows for “Guest Fill” logging of cylinders which are the property of another fire department

- › Handheld device can read both bar code and RFID tags. BAUER provides an RFID tag retrofit kit for cylinders which do not have embedded RFID tags. There is no limit to the number of SCBA cylinders or decentralized locations
- › Standard WIFI or optional LTE connectivity provides real-time communications with the BAUER RFIDPro™ Cloud
- › Offline functionality allows recording of data when WIFI or LTE signal is not available

BAUER RFIDPro CLOUD

- › Provides all required documentation and reports required by NFPA-1989 and OSHA-1910.134
- › Easy-to-use customer portal provides full administrative functionality including complete SCBA inventory management and reporting
- › Secure cloud-based data storage unique to each customer assures data integrity and compliance with data retention requirements. SSL data communication encryption between the RFIDPro server and client along with SHA-256 password encryption with optional two-factor password authentication provide the latest in state-of-the art network security



1 The BAUER RFIDPro handheld device performs all of the required functions in the field pertaining to the fill process

2 SCBA cylinder management is made easy through the user-friendly BAUER RFIDPro customer portal

SYSTEM BENEFITS

- › Assures fire department compliance with NFPA-1989 and OSHA-1910.134 associated with the SCBA cylinder fill documentation requirements
- › Facilitates 100% data accuracy by automatically recording and uploading all SCBA fill data to the cloud thus eliminating errors through manual data entry
- › Allows fire department administrators keep track and manage every aspect of their valuable SCBA cylinders in real-time including cylinder expirations, hydrotesting and repairs
- › Increases fire department personnel safety and efficiency by guiding them through the proper fill process and eliminating the workload associated with manually logging SCBA fills and inspections
- › Greatly reduces liability for fire departments associated with no or incomplete records, erroneous data or unsafe SCBA filling



BAUER CONNECT REMOTE TELEMETRY AND CONTROL VIA MOBILE APP

For over 75 years, BAUER has been the leader in breathing air products for firefighters. So we understand that every wasted minute leads to injury, smoke exposure, or worse. That's why we developed BAUER CONNECT IoT Solutions for Firefighting – our all-in-one, mobile telemetry solution for optimal ease-of-use and efficiency. Now you can view your SCBA fill data logs, get notifications about your compressor, and remotely control and monitor your BAUER compressor. The best part is that BAUER CONNECT can be tailored to fit your station's needs.

BAUER CONNECT – Connection that matters.

Security Features:

- › Multiple logical & physical security layers
- › Privilege and separation rights
- › AI/ML threat assessment & analysis
- › Transport layer encryption and encryption at rest
- › Extensive logging and monitoring of network, system and application events

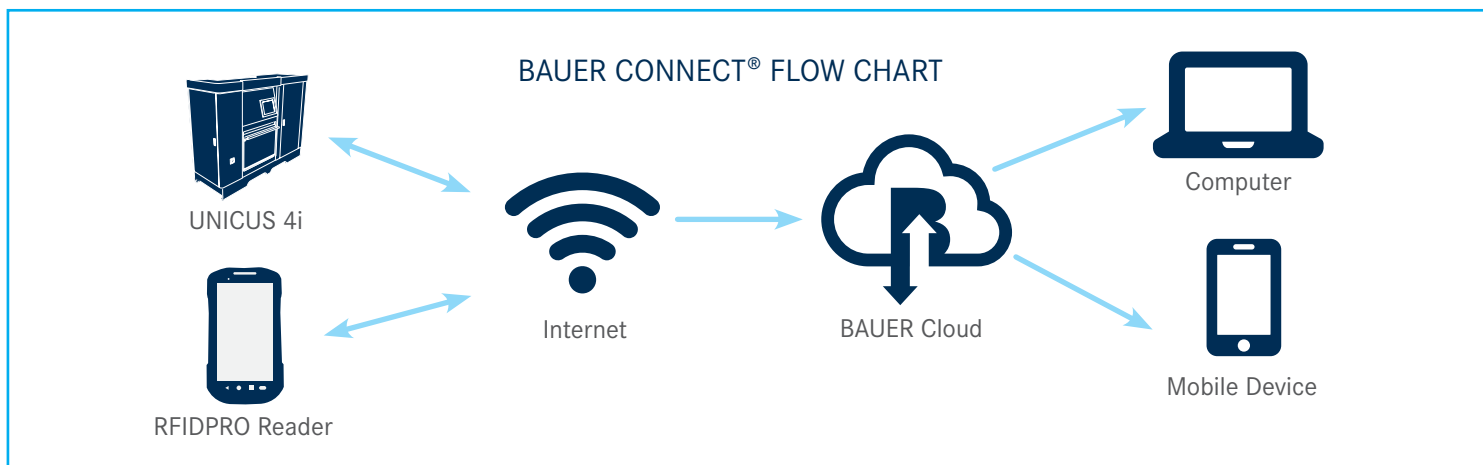

BAUER CONNECT® FUNCTIONS OVERVIEW



BAUER REPORTS

BAUER Reports is a function that generates custom reports tailored to the specific needs of the customer.

SCBA Management Report

- › Generate a report per NFPA 1989 data logging requirements
- › Show when your cylinders were last filled and by who etc.
- › Fill Status Warning: Lists the SCBA the cylinder in inventory that have not been filled within the year
- › Fill activity: Lists the SCBA cylinders serial number, Person filling, RFID serial, cylinder pressure and dates of fill
- › Personnel: List or edit admin, users with privilege to log in to BAUER CONNECT®



Compressor Reports

- › Temperature Trendline Report: Reports ambient temperature as well as temperature of every stage in the compressor



MOBILE DASHBOARDS

- › Quick reference of all of your BAUER compressors at your fingertips
- › Does not require password validation every time app is used
- › Total visual without the Remote HMI control capability (view-only option)
- › Dashboards can be customized to specific customer needs



NOTIFICATIONS

- › Fault on machine
- › Out of Date or Expired SCBA or SCUBA Cylinders
- › Text, email or push notification alarm(s)
- › Allows for instant, proactive steps to be taken if needed



BAUER REMOTE HMI

- › Live connect and remotely control any BAUER compressor(s) in your station
- › Secure log-ins - Only approved team members can access and control your compressor system
- › Saves time and money with instant control no matter your location



BAUER PREDICTIVE ANALYTICS

The BAUER Predictive Analytics capability provides a new proactive dimension to perpetually maintaining customers' compressor systems at peak conditions with minimum downtime. BAUER's Predictive Analytics algorithm uses artificial intelligence to analyze the collected breathing air system information on the BAUER Cloud to predict upcoming maintenance requirements and preventive actions to avoid unplanned shutdowns.



QUICK REFERENCE GUIDE

Model	Block	ACD	Gauges	Purification	Visual CO/ Moisture IND	Fill Assembly	Electrical Start	Hourmeter	Working Pressure
DIVE MATE® BASE									
DMTII 08-E1/E3	IK120II	–	–	P31	S	O	–	S	5000 PSIG
DMTII 08-GK	IK120II	–	–	P31	S	O	–	S	5000 PSIG
DMTII 08-DH	IK120II	–	–	P31	S	O	–	S (vibration type)	5000 PSIG
DMTII 10-E1/E3	IK12.14II	–	–	P41	S	O	–	S	6000 PSIG
DMTII 10-GK	IK12.14II	–	–	P41	S	O	–	S	6000 PSIG
DMTII 10-DH	IK12.14II	–	–	P41	S	O	–	S (vibration type)	6000 PSIG
DMTII 13-E1/E3	IK12.14II	–	–	P41	S	O	–	S	6000 PSIG
DMTII 13GK	IK12.14II	–	–	P41	S	O	–	S	6000 PSIG
DIVE MATE ELITE									
DMT08-E1/E3	IK120II	S	S	P31	S	O	–	S	5000 PSIG
DMT08-GK	IK120II	S	S	P31	S	O	S	S	5000 PSIG
DMT08-DH	IK120II	S	S	P31	S	O	–	S (vibration type)	5000 PSIG
DMT10-E1/E3	IK12.14II	S	S	P41	S	O	–	S	6000 PSIG
DMT10-GK	IK12.14II	S	S	P41	S	O	S	S	6000 PSIG
DMTII 10-DH	IK12.14II	S	S	P41	S	O	–	S (vibration type)	6000 PSIG
DMTII 13-E1/E3	IK12.14II	S	S	P41	S	O	–	S	6000 PSIG
DMTII 13-GK	IK12.14II	S	S	P41	S	O	S	S	6000 PSIG
DMTII 13 DH	IK12.14II	S	S	P41	S	O	S	S (vibration type)	6000 PSIG

Model	Block	ACD	Gauges	Purification	Securus	CO Mon	H ₂ S Mon	Fill Assembly	Electric Start	Working Pressure
OPEN DESIGNS										
K42-E3/42V-E3	IK22.0	S	S	P10	O	O	O	–	–	5000 PSIG
K60-E3	IK23.0	S	S	P12S	S	O	O	–	–	5000 PSIG
K80-E3	IK25.0	S	S	P14S	S	O	O	–	–	5000 PSIG
K145-E3	IK28.0	S	S	P14S	S	O	O	–	–	5000 PSIG
H35-E3/35V-E3	IK22.42	S	S	P10S	S	O	O	–	–	6000 PSIG
H80-E3	IK25.9	S	S	2x P10S	S	O	O	–	–	6000 PSIG
H96-E3	IK25.18	S	S	2x P10S	S	O	O	–	–	6000 PSIG
ENGINE DRIVEN										
H13-D	IK12.14II	S	S	P2S	S	O	O	–	S	6000 PSIG
H18-D	IK15.11II	S	S	P5S	S	O	O	–	S	6000 PSIG
K20-D	IK150II	S	S	P5S	S	O	O	–	S	5000 PSIG
H25-D	IK18.1II	S	S	P5S	S	O	O	–	S	6000 PSIG
K26-D	IK180II	S	S	P5S	S	O	O	–	S	5000 PSIG
H35-D	IK22.42	S	S	P10S	S	O	O	–	S	6000 PSIG
K42-D	IK22.0	S	S	P10S	S	O	O	–	S	5000 PSIG
K60-D	IK23.0	S	S	P12S	S	O	O	–	S	5000 PSIG

Model	Block	ACD	Gauges	Purification	Securus	CO Mon	H ₂ S Mon	Fill Assembly	Electric Start	Working Pressure
VERTECON®										
VEC05-E1/E3	IK100-420	S	S	P2	O	O	O	O	–	6000 PSIG
VEC08-E1/E3	IK120II	S	S	P31	w/P2	O	O	O	–	5000 PSIG
VEC10-E1/E3	IK12.14II	S	S	P2	O	O	O	O	–	6000 PSIG
VEC13-E1/E3	IK12.14II	S	S	P2	O	O	O	O	–	6000 PSIG
VEC18-E1/E3	IK15.11II	S	S	P5	O	O	O	O	–	6000 PSIG
VEC20-E1/E3	IK150II	S	S	P5	O	O	O	O	–	5000 PSIG
VEC25-E1/E3	IK18.1II	S	S	P5	O	O	O	O	–	6000 PSIG
VEC26-E1/E3	IK180II	S	S	P5	O	O	O	O	–	5000 PSIG
VERTICUS®										
VAC5-E1/E3	IK100-420	S	S	P2S	S	O	O	–	–	6000 PSIG
VAC8-E1/E3	IK120II-420	S	S	P2S	S	O	O	–	–	6000 PSIG
VAC10-E1/E3	IK12.14	S	S	P2S	S	O	O	–	–	6000 PSIG
VAC13-E1/E3	IK12.14	S	S	P2S	S	O	O	–	–	6000 PSIG
VAC18-E3	IK15.11II	S	S	P5S	S	O	O	–	–	6000 PSIG
VAC20-E3	IK180II	S	S	P5S	S	O	O	–	–	5000 PSIG
VAC25-E3	IK18.1II	S	S	P5S	S	O	O	–	–	6000 PSIG
VAC26-E3	IK12.180	S	S	P5S	S	O	O	–	–	5000 PSIG

Model	Block	Gauges	Purification	Storage Type	Storage Quantity	Add'l Storage	CO Mon	H ₂ S Mon	Remote Fill	Hose Reel	Working Pressure
VERTICUS® PLUS AND UNICUS® 4S											
VT-P 05-E1/E3	IK100-420	S	P2S	UN	2	–	O	O	O	O	6000 PSIG
VT-P 08-E1/E3	IK120II-420	S	P2S	UN	2	–	O	O	O	O	6000 PSIG
VT-P 10-E1/E3	IK12.14II	S	P2S	UN	2	–	O	O	O	O	6000 PSIG
VT-P13-E1/E3	IK12.14II	S	P2S	UN	2	–	O	O	O	O	6000 PSIG
UN 4/10-E1/E3	IK12.14II	S	P2S	ASME	2	O	O	O	O	O	6000 PSIG
UN 4/13-E1/E3	IK12.14II	S	P2S	ASME	2	O	O	O	O	O	6000 PSIG
UN 4/18-E1/E3	IK15.11II	S	P5S	ASME	2	O	O	O	O	O	6000 PSIG
UN 4/20-E1/E3	IK180II	S	P5S	ASME	2	O	O	O	O	O	5000 PSIG
UN 4/25-E1/E3	IK18.1II	S	P5S	ASME	2	O	O	O	O	O	6000 PSIG
UN 4/26-E1/E3	IK1180II	S	P5S	ASME	2	O	O	O	O	O	5000 PSIG

S standard O optional – option not available

PARTS



QUALITY AND RELIABILITY

Our factory-original replacement parts ensures when maintenance or repair is performed, you are restoring the unit to its original specifications and performance.

1. Purification
2. Gaskets and Seals
3. Lubricants
4. Fill Hose and Assemblies
5. Valves
6. Air Intake Filters
7. All 10,000+ Parts



7 PLUS, OVER 10,000 OEM PARTS

COMPATIBILITY

We configure our designs with interchangeability and our end user in mind. You can count on parts being available for all BAUER models.

PartsSales@BauerComp.com or 1-(844)-500-5822

GLOBAL SERVICE



- B** BAUER Germany & BAUER Norfolk
- BAUER Branches
- BAUER Service Centers/Distributors



SERVICE AND SUPPORT

Our compressors are designed with you in mind. Easy to use manuals guide you through clear, mechanically accessible repairs. Our worldwide distribution network was developed to assist in after-sales support, along with product and maintenance parts assistance.

FROM THE SOURCE

BAUER COMPRESSORS INC., is certified with **ISO 9001:2015** quality processes providing you with confidence that cannot be duplicated by sub-standard after-market parts and service.

TRAINING



BAUER COMPRESSORS INC. offers a variety of on site & off site Training Schools. Our on site classes are held at our BAUER Training Facility and are taught by the same people that help manufacture, test and service our products. From electrical systems to hands-on break downs, we cover all areas of compressor operation.

TRAINING TOPICS

Basic mechanical theory, control system theory (electric and pneumatic) along with troubleshooting for all BAUER systems.

Class schedule and course registration at:

www.BauerCustomerTraining.com



BAUER HELPDESK



MECHANICAL & ELECTRICAL

Total customer satisfaction is our top priority. BAUER provides 24-7 phone tech and troubleshooting support at our BAUER Helpdesk. Our support continues throughout our warranty period and beyond.

>>> For BAUER Helpdesk please email: CustomerService@BauerComp.com or call at:

+1 (844)-500-5822

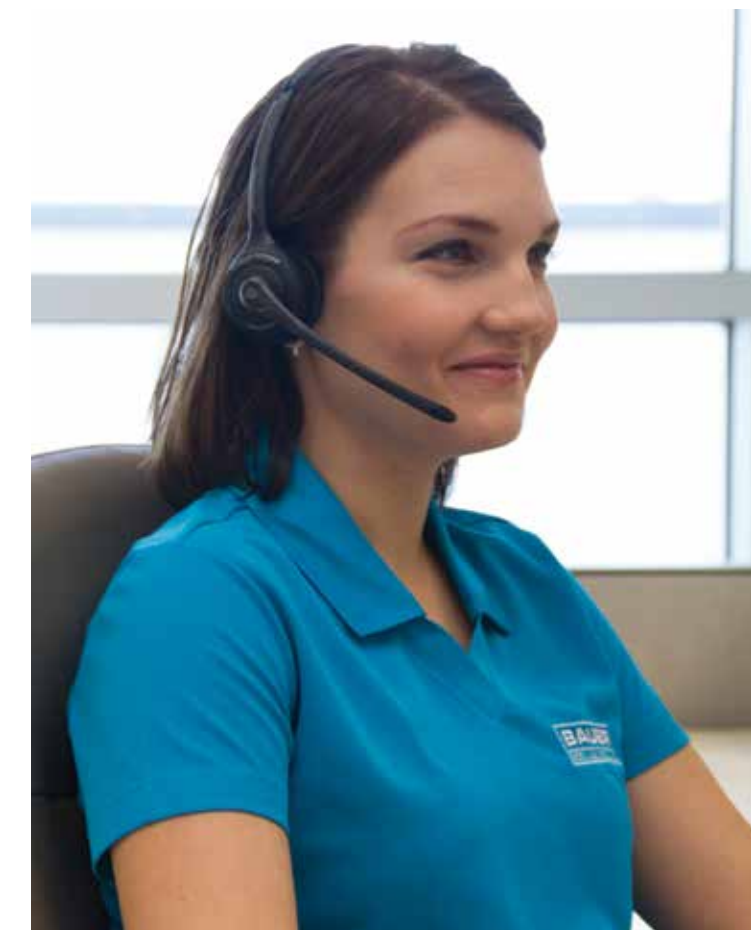

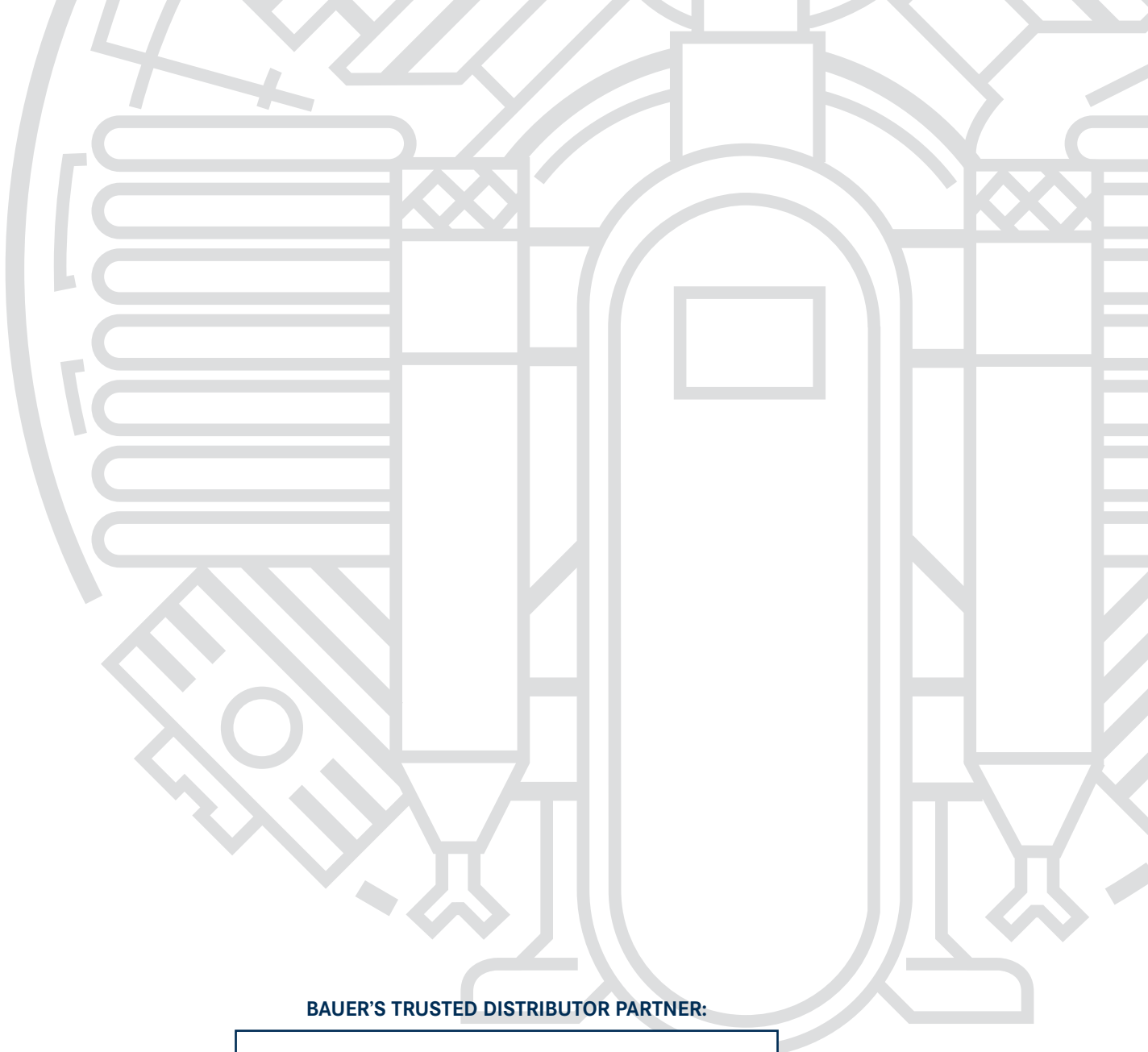

BAUER'S TRUSTED DISTRIBUTOR PARTNER:



SCAN TO DOWNLOAD THE PDF



U.S. HEADQUARTERS:
BAUER COMPRESSORS, INC.
1328 Azalea Garden Road
Norfolk, VA 23502
Tel. +1 (757) 855-6006
Fax +1 (757) 857-1041
SLS@BauerComp.com
www.BauerComp.com

U.S. BRANCHES:
BAUER MIAMI
Tel. +1 (954) 746-2504
Fax +1 (954) 746-2510
BFLSales@BauerComp.com

BAUER SAN FRANCISCO
267 East Airway Boulevard
Livermore, CA 94551
Tel. +1 (925) 449-7210
Fax +1 (925) 449-7201
BauerSF@BauerComp.com

BAUER NORTHEAST
2124 State Route 89
Seneca Falls, NY 13148
Tel. +1 (315) 568-5520
Fax +1 (315) 568-5520
Tim.Burgess@BauerComp.com

www.BauerBreathingAir.com

1174.04.24.2500
Subject to technical changes